

SOLAR ENERGY: A PROMISING SOLUTION FOR  
MEETING ENERGY DEMAND

WRITTEN BY

KAIZER DANIEL EMUEJEVOKE  
ND/ELECT/21/062

OF THE DEPARTMENT OF  
ELECTRICAL /ELECTRONIC ENGINEERING

SCHOOL OF ENGINEERING

A PROJECT SUBMITTED IN PARTIAL FULFILMENT OF THE  
REQUIREMENT FOR THE AWARD OF THE NATIONAL DIPLOMA  
(ND)

DECEMBER,  
2023

## DECLARATION

I **KAIZER DANIEL EMUEJEVOKE** with the Matriculation Number **ND/ELECT/21/062**, declare that this project on **SOLAR ENERGY: A PROMISING SOLUTION FOR MEETING ENERGY DEMAND** was carried out by me, that it is my original work and it has not been submitted wholly in part for the award of any certificate or degree in any institution.

KAIZER DANIEL EMUEJEVOKE

Signature date: .....

Confirmation by Supervisor

Name of supervisor: Engr. E. A. Yabefa

BAYELSA STATE POLYTECHNIC, ALEBIRI

## **DEDICATION**

I dedicate this work to Almighty God for provision, strength and long life throughout the period of this work and studies in Bayelsa State Polytechnic Aleibiri, Bayelsa State, Nigeria.

I also dedicate this work to my loving and caring parents for being ever supportive to my academic progress in every area.

BAYELSA STATE POLYTECHNIC, ALEIBIRI

## **CERTIFICATION**

This is to certify that the project titled “**Solar Energy: A Promising Solution for Meeting Energy Demand**” carried out by KAIZER DANIEL EMUEJEVOKE, has been read and approved for the Award of National Diploma In Electrical/Electronic Engineering Technology of Bayelsa State Polytechnic, Aleibiri, Bayelsa State, Nigeria.

Supervisor: Engr. E. A. Yabefa

Signature and Date: .....

Head of Department: Engr. Okosi Festus

Signature and Date: .....

Dean School of Engineering: Engr. E. A. Yabefa

External Examiner: .....

Signature and Date: .....

BAYELSA STATE POLYTECHNIC, ALEIBIRI

### **ACKNOWLEDGEMENT**

I wish to use this medium to first and foremost express my profound gratitude to my Heavenly Father who has been my strength and inspiration in life and in this academic endeavor.

I also want to thank and appreciate my Project Supervisor Engr. E. A. Yabefa, who's also the dean of faculty of school of ENGINEERING. Whose thorough supervision made this work a reality.

I own my parents, friends, colleagues, siblings who are always there for encouragement, financial and moral support to make me finish strong.

I also appreciate Engr. Okosi Festus my HOD who treated me as his own and offered me guidance and always pointed me in the right direction which will help me in and outside the polytechnic community.

BAYELSA STATE POLYTECHNIC, ALIBRI

## ABSTRACT

This project is titled solar energy: A promising solution for meeting energy demand

As the solar photovoltaic market booms, so will the volume of photovoltaic (PV) systems entering the waste stream. The same is forecast for lithium-ion batteries from electric vehicles, which at the end of their automotive life can be given a second life by serving as stationary energy storage units for renewable energy sources, including solar PV. The main objective of this paper is to systematically review the “state-of-the-art” research on the solar PV value chain (i.e., from product design to product end-of-life), including its main stages, processes, and stakeholder relationships, in order to identify areas along the value chain where circular strategies could be implemented, thereby advancing the transition of the PV industry towards circularity. Results shown that the PV value chain has been studied from a forward flow supply chain perspective and mostly from a technological point of view, with little regard for circular design, circular business models, and PV reuse. This article thus takes an integrated value chain perspective, introduces some of the barriers to circularity that industry players face, and argues that these barriers represent future opportunities for incumbent and new entrants to innovate within a circular PV industry.

**Keywords:** solar PV; EV batteries; circular economy; circular photovoltaic industry; PV reuse; PV recycling

## TABLE OF CONTENTS

Title Page	i
Declaration	ii
Dedication	iii
Certification	iv
Acknowledgement	v
Abstract	vi
Table of Content	vii
Table of Content	viii

### CHAPTER ONE: INTRODUCTION

1.1	Background of the study	2
1.2	Problem Statement	3
1.3	Aim of the Project	3
1.4	Objective of the Project	3
1.5	Significance of the Project to the Engineering Society	3
1.6	Significance of the Project to the Modern Society	5
1.7	Scope of the study	6

### CHAPTER TWO: LITERATURE REVIEW

2.1	Review of Project	8
2.2	History of Solar Energy in Nigeria	12

## **CHAPTER THREE: DESIGN AND CHARACTERISTIC PARAMETER**

3.1	Design	18
3.2	Types, Application and Components	20
3.2.1	Types of solar cell	
3.2.2	Application of solar PV	
3.2.3	Types of solar PV system	
3.2.4	Components of solar PV system	
3.3	System modelling	23
3.4	PV Power Plant Characteristic Performance	25

## **CHAPTER 4: PERFORMANCE STUDY OF PV POWER PLANT**

4.1	Comparative Performance Studies of Different PV Plants	28
4.2	Different Factors Affecting PV Power System Performance	29
4.3	Market status and PV quality	29
4.4	Solar Irradiance	33
4.5	Ambient and cell temperature	36

## **CHAPTER 5: RECOMMENDATION AND CONCLUSION**

5.1	Recommendation and future challenges	38
5.2	Conclusion	39

<b>REFERENCES</b>	42
-------------------	----

# Chapter 1

## INTRODUCTION

The use of photovoltaic (PV) systems, which convert light directly into electricity, has witnessed significant progress and widespread adoption in recent years. Distinct from other solar technologies like concentrated solar power or solar thermal, PV systems have become a mature and mainstream technology for electricity generation. These systems range from small rooftop installations to large utility-scale power stations, with most being grid-connected.

PV systems offer several advantages, including silent operation, no moving parts, and zero environmental emissions. They have proven to be a sustainable and clean source of renewable energy. In fact, a rooftop PV system can recover the energy invested in its manufacturing and installation within a short period and continue to produce approximately 95 percent of net clean renewable energy over a service lifespan of 30 years.

One of the driving factors behind the widespread adoption of PV systems has been the rapid decline in prices. Since their introduction, PV system prices have substantially decreased, although they may vary depending on the market and system size. For instance, in the United States, residential 5-kilowatt systems were priced around \$3.29 per watt in 2014. In the German market, where PV systems have achieved high penetration, rooftop systems up to 100 kW were priced at €1.24 per watt. Notably, the cost of PV modules now represents less than half of the overall system cost, with the remaining portion comprising balance of system components and soft costs such as customer acquisition, permitting, and financing.

Given the significant progress and market developments in PV systems, it is important to explore various aspects related to technology progress, market status, research and development, as well as strategies for enhancing the utilization and longevity of solar energy. This project aims to delve into these areas and provide valuable insights for optimizing solar energy systems to meet the needs of a wide range of consumers.

By examining the technological advancements, market trends, and research initiatives, this project seeks to contribute to the understanding of solar PV systems and their potential for long-term sustainability and widespread integration into the energy landscape.

## **1.1 Background of the study**

Solar photovoltaic (PV) systems have emerged as a key solution in the global pursuit of renewable energy sources. With the increasing concerns over climate change, the depletion of fossil fuels, and the need for sustainable energy alternatives, solar PV technology has gained significant attention and widespread adoption. This chapter provides an overview of the background and significance of solar PV systems, setting the stage for the subsequent research.

The first section of this chapter delves into the environmental challenges associated with conventional energy sources such as coal, oil, and natural gas. It highlights the detrimental effects of greenhouse gas emissions, air pollution, and the socioeconomic impacts of fossil fuel extraction. The need for transitioning to cleaner and more sustainable energy solutions becomes evident, leading to the exploration of solar PV systems as a viable alternative.

Next, the chapter explores the principles of solar PV technology. It explains how solar PV systems convert sunlight into electricity through the photovoltaic effect. The basic components of a solar PV system, including solar panels, inverters, and balance of system components, are discussed in detail. The section also provides an overview of different types of solar PV systems, such as grid-tied, off-grid, and hybrid systems, highlighting their respective advantages and applications.

Furthermore, the chapter outlines the significance of solar PV systems in the context of energy independence and security. It examines the decentralized nature of solar PV installations, which allows for local generation and consumption of electricity, reducing reliance on centralized power grids. The role of solar PV in rural electrification and remote area applications is explored, emphasizing the positive impact it can have on underserved communities.

The economic implications of solar PV systems are also investigated. The chapter discusses the declining costs of solar PV technology and the concept of grid parity, where solar electricity becomes cost-competitive with traditional grid-supplied electricity. It analyzes the potential economic benefits of solar PV systems, including job creation, reduced energy expenditures, and the stimulation of local economies.

Finally, it outlines the objectives and scope of the research project. It presents the research questions that will be addressed throughout the study and provides a brief overview of the subsequent chapters. The importance of the research in advancing knowledge, informing policymakers, and contributing to the field of solar PV systems is emphasized.

## 1.2 Problem Statement

Solar PV technology has gained significant attention in recent years due to its potential to provide clean and renewable energy. However, several challenges hinder its widespread adoption and efficient utilization. This project work seeks to shed light on these problems and propose potential solutions. Let's delve into the key problems that this project can solve.

## 1.3 Aim of the Project

The aim of the project is deriving a means of making solar energy a promising solution for meeting energy demands.

## 1.4 Objectives of the Project

The objectives of the project is understanding and deriving a means of making solar energy a promising solution for meeting energy demands.

The objectives of the research project on solar PV systems are crucial in defining the specific aims and boundaries of the study.

## 1.5 Significance to the Engineering Society

The transition to renewable energy sources, such as solar photovoltaic (PV) systems, is crucial for addressing the pressing global challenges of climate change, energy security, and sustainable development. As the world faces the need to reduce greenhouse gas emissions and shift away from fossil fuels, the role of solar PV technology becomes increasingly significant. This project on solar PV systems holds great importance in serving and improving the engineering society in several ways:

- ❖ **Advancing Sustainable Development Goals:** The project aligns with the United Nations' Sustainable Development Goals (SDGs), particularly Goal 7 (Affordable and Clean Energy) and Goal 13 (Climate Action). By exploring the potential of solar PV systems, the project contributes to the development of clean, affordable, and reliable energy solutions. This is essential for promoting sustainable development and addressing the energy needs of communities worldwide.
- ❖ **Promoting Environmental Stewardship:** Solar PV systems offer a clean and renewable energy alternative, reducing reliance on fossil fuels and mitigating harmful environmental impacts. By studying and improving solar PV technology, the project aims to promote environmental stewardship. The findings and recommendations can guide the engineering society in adopting sustainable energy practices, leading to a significant reduction in carbon emissions and preserving natural resources.

- ❖ **Encouraging Technological Innovation:** As an engineering-focused project, it actively fosters technological innovation. By investigating the progress and advancements in solar PV systems, the project contributes to the development of cutting-edge technologies, materials, and manufacturing processes. This knowledge can inspire engineers and researchers to push boundaries, explore new possibilities, and drive further innovation in the field of renewable energy.
- ❖ **Enhancing Energy Access and Affordability:** Access to reliable and affordable energy is a fundamental requirement for socio-economic development. Solar PV systems have the potential to provide electricity to remote and underserved communities, overcoming the limitations of traditional grid infrastructure. By identifying ways to improve solar PV efficiency, durability, and cost-effectiveness, the project can contribute to enhancing energy access and affordability, particularly in developing regions.
- ❖ **Strengthening Energy Security:** Diversifying the energy mix by incorporating solar PV systems enhances energy security. By reducing dependence on fossil fuel imports and vulnerable centralized power generation, countries can achieve greater energy independence. The project's findings and recommendations can support the engineering society in designing resilient and decentralized solar PV systems, thereby strengthening energy security and reducing vulnerabilities associated with traditional energy sources.
- ❖ **Fostering Economic Growth and Job Creation:** The widespread adoption of solar PV systems creates opportunities for economic growth and job creation. The project's research on the market status and economic viability of solar PV can inform policymakers, businesses, and investors about the potential benefits. By encouraging the engineering society to invest in solar PV projects, it can stimulate economic activity, drive local job creation, and contribute to a sustainable and resilient energy sector.
- ❖ **Facilitating Knowledge Transfer and Collaboration:** The project provides a platform for knowledge transfer and collaboration among engineers, researchers, industry experts, policymakers, and other stakeholders. By disseminating research findings, best practices, and technological advancements, it contributes to a collective understanding of solar PV systems. This knowledge sharing facilitates collaboration and encourages interdisciplinary approaches to address the complex challenges of energy transition effectively.

## 1.6 Significance to the Modern Society

The project on solar PV systems goes beyond serving and improving the engineering society; it also holds immense importance in serving and improving the world and society at large. The global challenges we face today, such as climate change, energy poverty, and environmental degradation, require innovative solutions that can make a positive impact on a global scale. This project plays a crucial role in achieving these objectives in the following ways:

- ❖ **Mitigating Climate Change:** Climate change is one of the most pressing issues of our time, with far-reaching consequences for ecosystems, economies, and human well-being. By promoting the adoption of solar PV systems, the project contributes to mitigating climate change by reducing greenhouse gas emissions. Solar energy is clean, renewable, and abundant, providing an alternative to fossil fuels and helping to decarbonize the energy sector. The project's findings and recommendations can guide policymakers, businesses, and individuals in transitioning to sustainable energy sources, thus making a significant contribution towards combating climate change.
- ❖ **Advancing Energy Access and Eradicating Energy Poverty:** Access to modern and reliable energy services is essential for human development and well-being. However, a significant portion of the global population still lacks access to electricity, particularly in remote and underserved areas. By focusing on solar PV systems, which can be deployed off-grid or in decentralized systems, the project aims to improve energy access and eradicate energy poverty. Solar energy can provide clean electricity to communities that are not connected to the centralized grid, empowering individuals, supporting education and healthcare services, and driving socio-economic development.
- ❖ **Promoting Sustainable Development:** The project aligns with the principles of sustainable development, which seek to meet present needs without compromising the ability of future generations to meet their own needs. Solar PV systems offer a sustainable energy solution that can power homes, businesses, and industries while minimizing negative environmental impacts. By exploring ways to enhance the efficiency, durability, and affordability of solar PV technology, the project promotes sustainable development by enabling the transition to clean energy sources and supporting the achievement of the United Nations' Sustainable Development Goals.
- ❖ **Improving Air Quality and Public Health:** The project's focus on solar PV systems contributes to improving air quality and public health. Traditional energy sources such as fossil fuels release harmful

pollutants into the atmosphere, leading to air pollution and associated health issues. By replacing these sources with solar energy, the project helps reduce air pollution, including the emission of particulate matter, sulfur dioxide, nitrogen oxides, and other harmful pollutants. Improved air quality has significant benefits for public health, leading to lower rates of respiratory diseases and creating a healthier and more sustainable living environment for communities.

- ❖ **Fostering Technological Transfer and Capacity Building:** The project facilitates technological transfer and capacity building, particularly in regions where solar PV systems are underdeveloped or not yet widely adopted. By sharing knowledge, best practices, and technological advancements, the project supports the transfer of expertise and empowers local communities to develop and implement solar PV projects. This technology transfer enhances local skills and capabilities, promotes entrepreneurship, and creates opportunities for innovation and economic growth.
- ❖ **Encouraging Global Collaboration and Cooperation:** Addressing complex global challenges requires collaboration and cooperation on an international scale. The project acts as a catalyst for global collaboration by bringing together researchers, engineers, policymakers, and stakeholders from different countries and disciplines. Through collaborative efforts, the project can facilitate the exchange of ideas, experiences, and resources, leading to the development of comprehensive and effective strategies to address energy and sustainability challenges worldwide.
- ❖ **Inspiring a Sustainable Mindset and Behavioral Change:** The project has the potential to inspire a sustainable mindset and drive behavioral change among individuals and communities. By raising awareness about solar PV systems and their benefits, the project can influence attitudes and behaviors towards clean energy adoption. It can encourage individuals to make environmentally conscious choices, such as installing solar panels on their rooftops or supporting renewable energy policies and initiatives. These individual actions, when combined, can have a collective and transformative impact on society, leading to a more sustainable and resilient world.

## 1.7 Scope of the Project

The scope of this research project encompasses a comprehensive analysis of solar PV systems, technology progress, market status, and research and development efforts. It will draw upon a wide range of sources, including scientific literature, industry reports, market data, and case studies. The

research will focus on the global perspective, while also acknowledging regional variations and specific market dynamics.

The limitations of the research project should also be acknowledged. Due to the vastness of the topic, it may not be possible to cover every aspect of solar PV systems in depth. Additionally, the dynamic nature of the solar industry means that the information presented in this study may evolve over time. Nonetheless, the research project aims to provide valuable insights into solar PV systems and contribute to the existing knowledge base.

BAYELSA STATE POLYTECHNIC, ALEIBIRI

## Chapter 2

### Literature review

#### 2.1 Review

Photovoltaic (PV) power plants utilizing solar energy to generate electricity on a large scale has become a trend and a new option that has been adopted by many countries [Adnan et al, 2022]. The global power sector has been facing difficulties in terms of fulfilling the energy demand due to the increasing population and technology growth [Razi and Ali, 2019, Adnan et al, 2022]. Moreover, conventional primary sources of energy, such as oil, coal, and natural gas, have a severe negative impact on the environment [Aslam et al, 2021]; therefore, the global community is looking for, and examining, sustainable and clean energy sources that can meet energy demands. Renewable energy sources have gained popularity over the past 20 years, as they are abundant and environmentally beneficial sources of electricity [Sengupta et al; Adnan et al, 2022]. Thus far, solar energy is the most promising renewable source of energy, and worldwide, its popularity has vigorously grown. The basic schematic diagram of a solar PV system is shown in the figure below

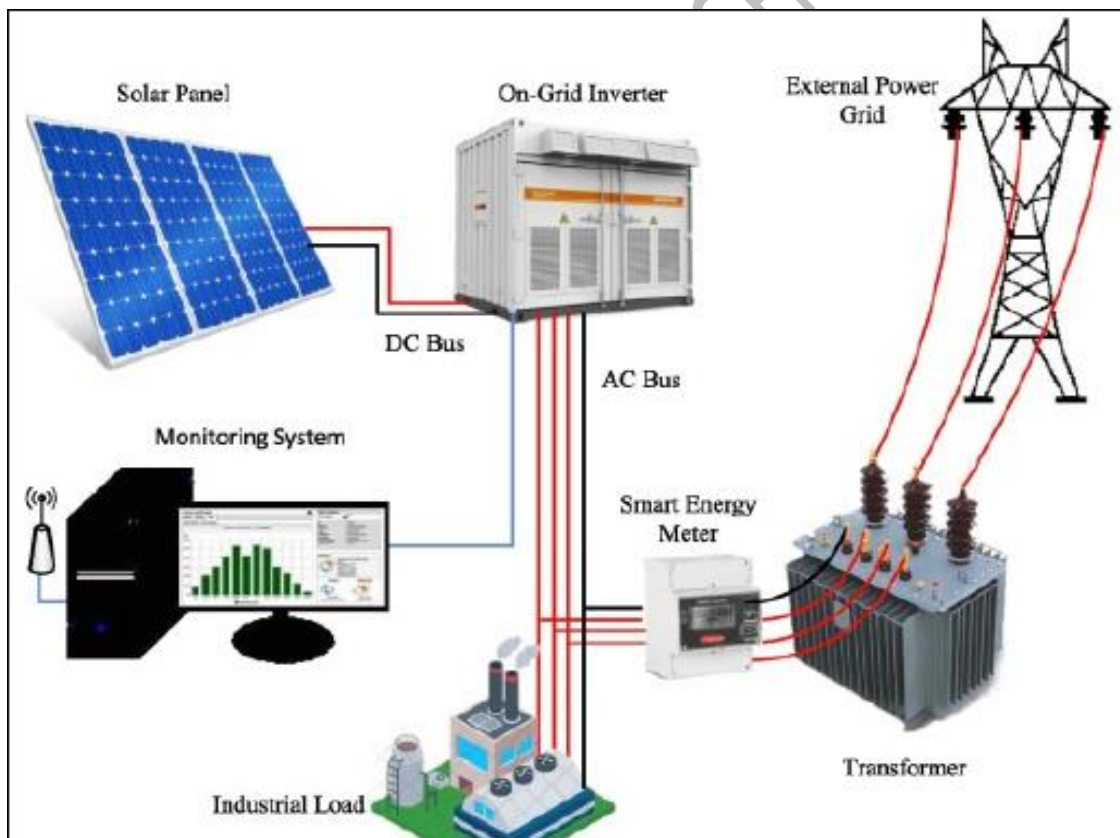

**Figure 2.1** PV plant schematic diagram [Aslam et al, 2021]

The actual conversion efficiency of a PV power system is not same as under standard test conditions due to external dynamic weather conditions

[Agrawal et al, 2022]. Moreover, solar irradiance, tilt angle, ambient temperature, dust, and shading effects, among other factors, also have a negative impact upon the performance of PV power system [Atsu et al, 2020]. Researchers have worked hard to identify several strategies for reducing the negative effects of these factors. Indeed, monitoring the performance of already installed PV power plants from a wider perspective is essential for the accurate projection of power generation from photovoltaic systems. However, there is a significant access gap in electrical energy globally where about 1.3 billion people live without electrical energy [Karakaya and Sriwannawit, 2015]. Sub-Saharan Africa accounts for over 600 million people of the population of people living without electricity, which can be attributed to the poor development progress, both in technological development and human development, of the sub-Saharan Africa nations [Stern, D.I. and Cleveland, C.J, 2004].

PV systems are now seen as important options for bridging the gap between the current electrical energy supply and demand through a wide range of applications [Dawn et al, 2016]. PV systems have gained significant acceptance and application in the developed nations with Germany leading the pace, after China, having installed capacity of about 40 GW [Wirth, H. 2016]. However, Africa's total cumulative installed capacity of PV at the end of 2015 remains very low at 2.1 GW, which amounts to just above 5% of Germany's installed capacity. This comparatively low penetration level is paradoxical given that countries across Africa are endowed with abundant solar insolation levels.

Nigeria lies between 4 - 14°N and 3 - 15°E with a land area of about 923,800 km<sup>2</sup>. Nigeria is the most populous country in Africa with about 170 million people and comparatively very large primary energy potentials. However, Nigeria is useful-energy starved as only about 10% of the rural dwellers and 40% of the urban dwellers have access to the national electricity grid supply [Federal Ministry of Power, 2015]. Nigeria has the highest duration of a power outage in Africa [World Bank, 2015]. Out of the projected daily peak electricity demand of 25,800 MW in Nigeria, the average daily peak supply is 3140 MW—87.8% unsatisfied projected demand—with about 20% distribution/transmission loss. Specifically, the total installed capacity of the power plant is currently at 12,522 MW; whereas, non-available capacity is about 5500 MW and non-operational capacity is about 3200 MW [US Energy Information Association, 2016]. The figure below show the energy consumption in the economic sector of Nigeria 2011-2014

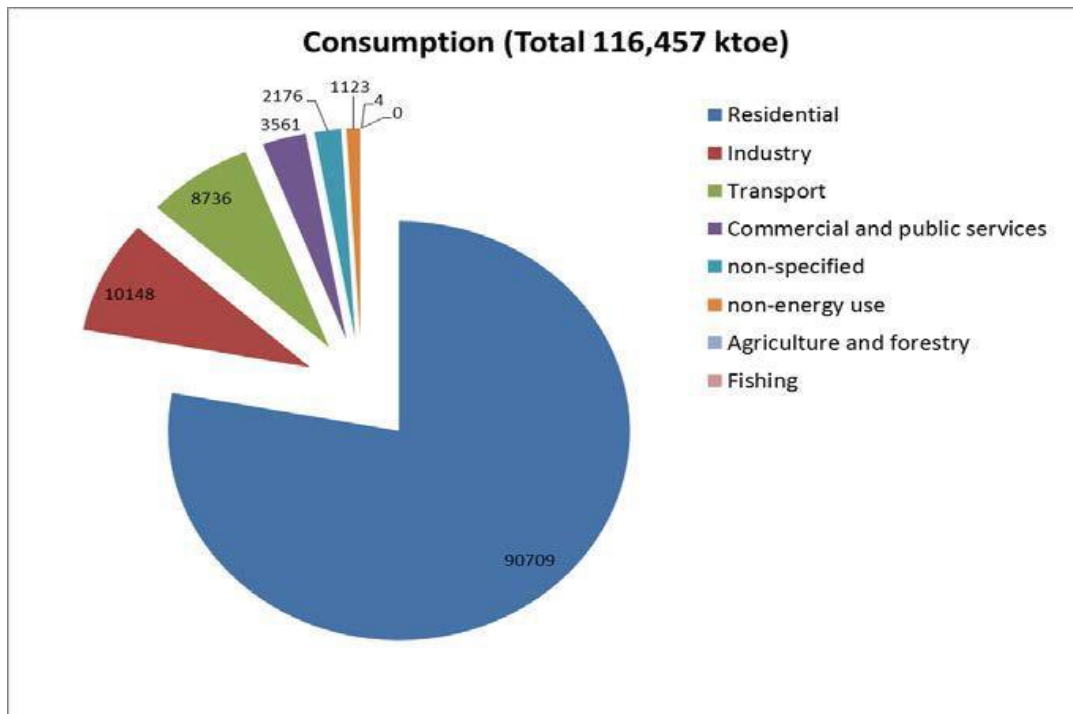

**Figure 2.2** Energy consumption in Nigeria 2011-2014  
[Udejah et al, 2021]

Electricity supply in this country has been erratic and epileptic thus resulting in frequent power outages that have impaired economic growth and development. The residential, commercial and industrial electricity consumption accounted respectively for 51.3, 26.7 and 22 percent of total electricity consumption. The supply of electricity to the residential sector and other sector at large is getting declined; this can be attributed to the increase in population and drastic decrease in electricity generation. Most residential building buildings owners have resorted to the use of diesel generator and of recent, the use of solar photovoltaic installations and inverter system as an alternative/ backup to the epileptic power supply. The industries are moving out of the country to neighboring countries with a more reliable power supply, this has led to high cost of goods and services in this country [Adenikinju, 2003]. Nwachukwu *et al.* (2014) determined the electricity consumption pattern in south-south geopolitical region of Nigeria. The results showed that there were significant differences in electricity consumption pattern amongst the six states that constitute the geopolitical region. River state had the highest mean consumption rate, followed in descending order by Delta, Edo, Akwa Ibom, Bayelsa and Cross River states. He recommended for strategic and systematic distribution of electricity to ensure adequate supply in south-south geopolitical region. Arimah (1993) discovered that that there was spatial variation in electricity consumption in Nigeria. This, he attributed to variation in socio-physical variables among various regions. These variables are the price of electricity, urbanization, income, population, number of residential houses, land area, commercial activities, industrial activities and distance of each state to Kanji Dam. Donatos and Mergos (1991) examined the

determinants of residential consumption in Greece over the period 1961 – 86. The result showed that: first, the residential demand for electricity was price inelastic but income elastic. Second, there was high substitutability between electricity and liquefied natural gas. Third, during the examined period, the number of consumers played a very important role in the expansion of electricity consumption in Greece. Fourth, there was no regional variation in residential electricity demand. Similarly, Tserkezos (1992) studied household electricity consumption in Greece. The results showed that personal disposable income, prevailing temperature and price of electricity used by the household played an important role in the demand for electricity. Tiwani (2000) determined the short run residential demand for electricity using household survey data for Bombay (Mumbai), India. Holtedahl and Joutz (2004) showed that residential demand for electricity in Taiwan was a function of household disposable income, population growth, the price of electricity and the degree of urbanization. In the long-run, the income was inelastic and the own-price effect was negative and also inelastic. Due to the lack of reliable electricity, many people and companies supplement the electricity provided by the grid system with their own generators. In fact, most everyone who can afford a generator owns one. According to one approximation, well over 90% businesses have generators. Kennedy-Darling *et al* (2008) opined that the electricity from private generators is more expensive than that from the national power grid, thus raising the price of domestic goods. Efforts to alleviate this strain are met with opposition from the companies who import generators, as they have created an extremely lucrative industry. There is suspicion that some of the grid system sabotage is from members of this industry.

The utilization of solar energy depends on its availability and appropriate technology. The idea of using the sun's power has held scientist in its grips for centuries. Also, for most of its evolution, mankind relied for its sources of energy on constantly replenished materials. When the use of fire was discovered for the provision of heat and for the processing of food, the additional demand for energy was met by constantly renewed sources. Later still when water and wind powers were harnessed to the service of mankind, the new sources were also of a renewable nature. Thus throughout the early phase of human development, the availability of the readily renewable sources of energy was a key constraint and affected the size and distribution of population [Sambo, 2001].

The sun radiates enormous amount of energy. It radiates energy in one year than people have used since the beginning of times. It takes millions of years for the energy in the sun's core to make its way to the surface, and then, just a little over eight minutes to travel to the earth. Solar energy travels to earth at the speed of light. Only a small amount of the energy radiated by the sun strikes the surface of the earth; one part in two million. Yet, this amount of energy is enormous. Enough solar energy strikes the earth to supply its energy needs. In 1831, it was discovered that the sun's energy could produce a photovoltaic effect.

In 1878, solar to mechanical conversion was first demonstrated when sunlight was concentrated by focusing a collector on a steam boiler that ran a small printing press. [El-Wakil as cited by Abdulkarim, 2004]. In the 1980s, selenium photovoltaic cells were developed that could convert sunlight into electricity with 1-2% efficiency but how the conversion was done was not understood. Solar power therefore remained a curiosity for sometimes. In 1901, larger focusing collector in the form of truncated cone generated steam for a 4.5hp engine. Between 1907 and 1911, solar steam engine of several HP that were used for pumping water were built. Liebowitz and Hanseth (1982) has it that by mid 1950s the efficiency of 45 and later 11% had been achieved with silicon photovoltaic cells. From then, interest in solar power intensified. During the late 1950s and 1960, the space program took active role in the development of photovoltaic. The cells were perfect sources of electric power for satellite because they were rugged, lightweight and could meet the power requirements reliably. Unfortunately, the cells were not practical on earth due to the high cost of making them efficient and lightweight. Consequently, further research was needed.

## **2.2 History of Solar Energy in Nigeria**

Nigeria is entirely between the equator and the tropic of cancer. Nigeria's electrical energy consumption in the year 2001 is  $15 \times 10^6$  kWh [Ojo, 2000 as cited by Ajayi 2009]. Its climate varies from tropical to subtropical. There are two main seasons; the dry season lasting from October to March and the rainy season lasting from April to October. In the north, it is hot and dry, rainy season extends between April and September. In the south, it is hot and wet, rainy season extends between March and December. From December to March there is a long dry season. Temperature at the coast rarely rise above 32 °C. The north is drier with temperature range between 32 °C and 42 °C humidity is about 95% [Ajayi, 2009]. The sun has been shining for about 4.5 billion years. It has enough hydrogen to burn for about 10 billion years. All energy on earth is direct or indirect result of sun's energy. The sun's ultraviolet rays are absorbed by green matter of plant to make them grow.

The first concern to the designer of solar energy system is the availability of that solar energy in that region at present and at some other time in the future. The availability of solar energy on earth depends on geographical location and time scale. The sunshine hours and consequently the radiations in different zones differ. The sun's power reaching the earth is typically about 1000W/m<sup>2</sup>.

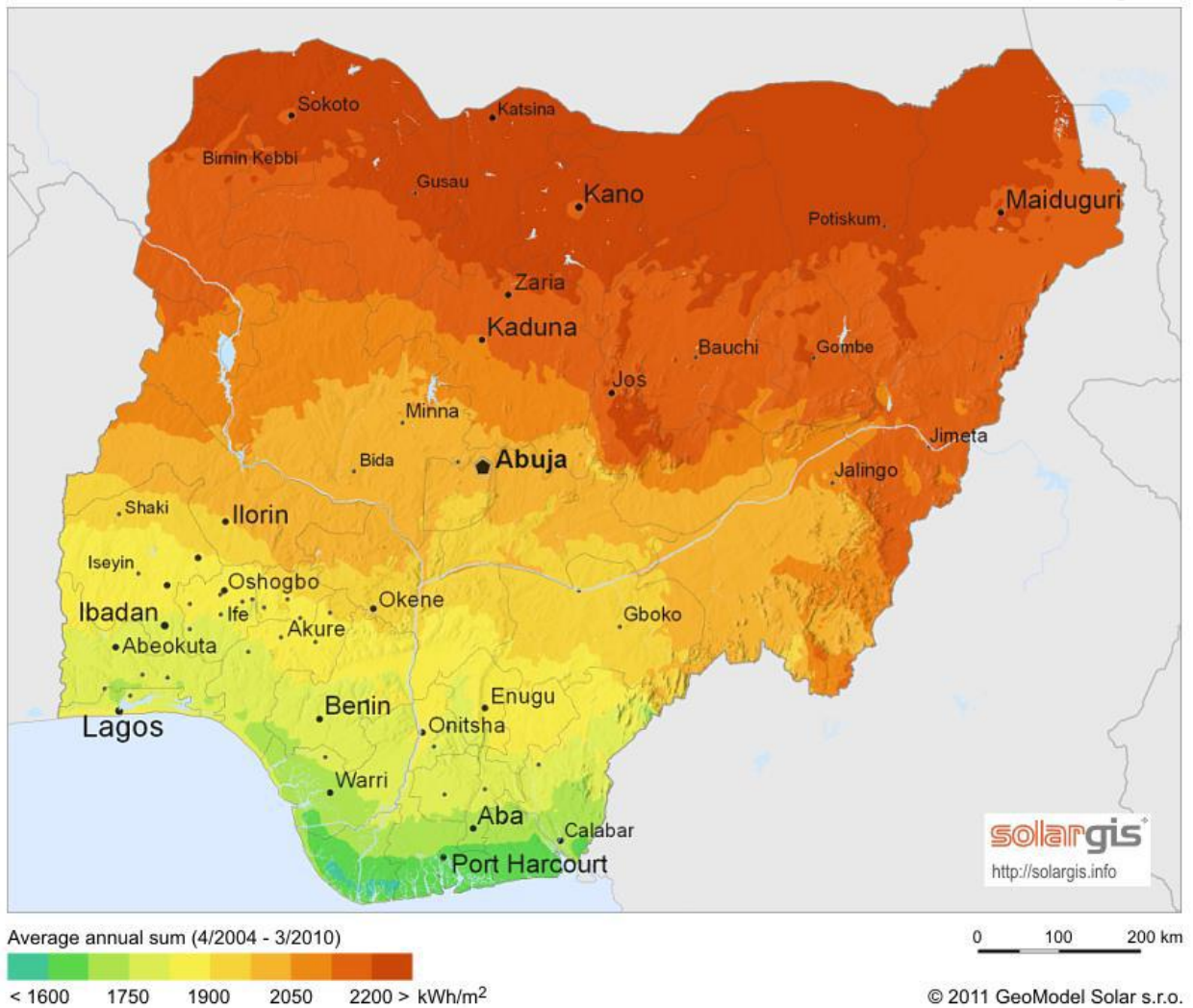

**Figure 2.3** Irradiation in Nigeria  
Source [solargis.info 2017]

The rapid increase of the world population and present-day industrial development and lifestyle have created a massive demand and energy supply gap. This gap demands a rapid increase of substantial clean, stable, and reliable energy supply. The over-dependency on depleting fossil fuel in generating energy for our daily demand increasingly affects our environment and deteriorates human health. Access to stable and reliable energy is still a dream for most developing countries, and its deficiency is ominous for development, as energy access is crucial to economic development, socio-economic activities, agricultural activities, and living standard [Akinyele et al, 2015].

Nigeria is endowed with conventional energy resources (Non-Renewable) and renewable energy resources (Biomass, Hydro, Solar, and Wind) that are sufficient to satisfy the demand of its populace and export the excess to neighboring countries as a tradable commodity to generate funds. Thus far, the in-house supply is still inadequate and unable to meet the country's

demand, and this is continuously increasing due to a continuous increase in population, requiring an immediate response before it reaches an unrecoverable situation. This inadequacy of supply has several consequences. The Nigerian government has disbursed billions of dollars over the last two decades to improve and boost energy supply using conventional energy resources, yet the country is still plagued with severe energy shortages [Usman et al., 2015]. The numerical value relating to some investments is provided in this report's subsequent section. This energy supply shortage poses challenges to both the rural and urban populations. However, the problem is most severe in the rural areas, where the majority of the population lives without access to the national grid, and besides, even the majority of urban dwellers suffer from an unstable and insufficient power supply. The frequent power outages have compelled many Nigerians to adopt self-energy generation using various fossil fuel-powered generators to generate electricity for domestic, commercial, and industrial consumption. The by-products of this have adverse effects on humans and the environment.

Moreover, Nigeria's energy poverty is very alarming [Edomah et al., 2021], with some reports describing the electricity's performance records as appalling; thus, it becomes imperative for unceasing research on the energy situation to provide possible solutions to mitigate the problem. Worldbank (2021) also stated that many people live without access to the grid, making the situation very concerning, affecting the citizens and economic growth of the country. Several types of research have been conducted to explore the potential of clean and reliable energy in Nigeria. Sambo (2009) stated that clean energy is the solution for Nigeria's acute energy crisis, predominantly in rural areas. Ajayi and Ajayi (2013) stated that fossil fuel by-products are harmful to humans and the deleterious environment. Aliyu et al. (2015) also believe that there is a need to rigorously pursue renewable energy technology to conquer Nigeria's continuing energy deficit to progress. Such renewable energies as clean energy should be considered viable options for sustainable electricity production in Nigeria.

As earlier stated, rapid population growth has made the energy demand increase beyond the supply in Nigeria. The country has suffered from this energy deficit for over two decades. The majority of the populace does not have access to the national utility grid and are left with the option of self-energy generation using firewood and/or fossil fuel that significantly affects both the environment and its inhabitants. The exploitation of renewable energy to compensate for the rapid increase of population, especially in the country's remote areas, could be a solution [Mohammed et al., 2013]. Several prior studies have established that a sufficient and stable energy supply is vital to any country's development. Without the minimum required access to energy for many of its population, a nation cannot develop and sustain itself beyond a subsistence economy. Prior studies show that renewable energy can resolve the persisting energy crisis in the country that has lasted for over two decades. Some of these research papers are as follows: Shaaban and Petinrin (2014) concluded that the country is suffering from an acute electricity deficit and advocate that the use of renewable energy can solve the persisting energy

crisis in the country by bridging the demand and supply gap as well improving the living standards of the people residing in the rural areas. Ohunakin (2010) studied the current and future perspectives on renewable energy application in Nigeria.

The research concluded that energy demand is very high and continuously increasing because of the continuous increase in the population. The researcher further recommended exploiting the renewable energies available and diversifying the energy supply. Anumaka (2012) concluded that the Nigerian government alone could not provide adequate funding to supply electricity. They recommended that private and foreign investors are required to promote the integration of renewable energy to minimise low access to electricity in rural areas. Mohammed et al. (2013) concluded that renewable energy could serve as a solution to the energy poverty in the rural areas and further recommended that in order to keep with the pace of rapid population growth in the country, there is a need to exploit renewable energy to compensate for the energy deficit. Ajayi et al. (2016) conducted an assessment of solar and wind resources' potentials in Northern Nigerian and concluded that solar photovoltaic technology is a viable option to facilitate sustainable development goals. Akimbami (2001) conducted an analytical review of renewable energy policies in Nigerian. The researcher concluded that renewable energy resources could decentralise energy supply and increase energy security.

Akuru et al. (2017) highlighted the potential of renewable energy in Nigeria and concluded that a 100% renewable energy supply is possible in Nigeria because it has already been achieved elsewhere; however, it requires a substantial financial commitment. As reported by Dodondawa (2019) and Daily\_Trust (2019), the Managing Director of Shell Nigeria Exploration and Production Company (SNEPCO), Mr Bayo Ojulari, stated that Nigeria requires approximately USD 40 billion to USD 200 billion so as to close the energy gap which would provide 30 gigawatts (GW) to 175 GW generation capacity. However, this estimation does not specify if the generation is renewable or not but is exceptionally huge.

Aliyu et al. (2015) reviewed and presented the current status of Nigeria's primary renewable energies and their potentials. They recommended and promoted the integration of renewable energy in the supply mix. Ikem et al. (2016) presented an overview of the Nigerian national electricity grid, concluded an inadequate flow of information regarding renewable energy, and recommended that the Nigerian government pursue the renewable energy policy yet implemented. The research further stated that renewable energy resources could also increase reliable and stable supply, sustaining its growth. Sambo (2009) presented the role of renewables in bridging the energy demand and supply gap.

A common approach normally taken by researchers is to perform first, a meta-analysis, within frameworks which studies several factors of diffusion of

technology. Often the result produced is a generalized list of barriers and drivers. In addition factors influencing diffusion of technology are treated based on the research strategy adopted by the researcher. On the other hand a diffusion of technology research which is case study specific often produces a list of drivers and barriers which are peculiar to the context of study with regards to location, period, and prevailing circumstances within the given geographical location. For example Juan Leandro del Viejo Dominguez (2011) revealed that initial high cost, is not the only problem for solar energy development in Nigeria, rather to large extent misallocation of efforts and resources. Where less resource is committed to research and development of solar products suitable for the Nigerian climatic conditions, as products and parts are normally imported. Juan attributed other problems such as lack of awareness of solar energy in rural areas, sub-standard products in the market, and highlights the problem of much investments and focus by the Nigerian government on research on solar energy instead of implementation of pilot projects. Juan also pointed out that the Nigerian market would require a push in the form of financial schemes and subsidies. Framework articles played an important role in identifying, categorizing and formulating a broad layout of barriers and drivers.

Olalekan et al (2012) investigated the diffusion of solar PV into the Nigerian rural energy mix in six remote villages, with results showing that the use of solar PV was 49.9kwh/day, which constituted an insignificant share of about 14% in the total lighting requirement and less than 2% of the total required energy services. The analysis further revealed a significant rise in demand to 73.3kwh/day by 2019 at the same share of the total lighting requirement. Firewood demand maintained over 80% share (2383.5 kwh/day) in the total energy mix 2009. Conclusion from the study revealed that an increased use of solar PV for lightning, entertainment, refrigeration and ventilation in the areas studied could lead to decrease in the use of energy from alternative sources. The advantage literatures with specific case studies brought was that it provided incisive details, thoroughly explaining each factor which resulted in better understanding of prevailing factors from a narrow and local perspective.

Ijeoma vicent-Akpu (2012) noted that sound government policy, public acceptance, technical and financial capability, will play a major role if the use of renewable energy would be successful in Nigeria.

Over time efforts have been made by the government to eliminate obstacles which hinder private sector investment for example the provision of Federal government of Nigeria (FGN) credit enhancement, establishment of bulk purchaser, establishing an appropriate licensing regime, clarifying and strengthening the licensing regime, ending the trend of inconsistent policy implementation etc, to increase private sector participation and encourage renewable energy growth. Nevertheless barriers basically due to technical capability and access to finance need to be overcome for this to become successful [Sambo 2009].

Hakeem A. Bada 2011 analyzed the policies and limitations towards facilitating the use of renewable technologies in Nigeria and his conclusion was barriers were ranging from environmental issues, technical issues, and political issues in addition to economic and social issues.

The policies developed till now for the broad dissemination of solar PV systems are briefly mentioned. Moreover, the barriers that impede the dissemination are also discussed and classified into eight categories. The policymakers and researchers can easily detect the most unfavourable barriers and take necessary

steps to overcome these. The classified eight types of barriers are policy and regulatory, institutional, technical, information, financial, lack of human resources, lack of adequate research activities and proper management.

The benefit of solar energy remains enormous even when compared to other forms of renewable energy forms. For example wind turbine, though a renewable energy source, normally have the associated problem of noise during operation, requiring open and spacious areas for installation while photovoltaic cell can easily be mounted on rooftops. Wind turbines also require much more maintenance than photovoltaic cells.

Hydroelectricity on the other hand, although from a renewable source, offers less benefit when compared with solar energy. Given the fact that for hydroelectricity to be supplied it requires construction of dams, which are expensive and building dams affects aquatic life and has the potential of altering an entire ecosystem.

## Chapter 3

### Design, Component, Modelling and Characteristic Parameter

#### 3.1 Design

This device uses photovoltaic effects when exposed to solar radiation to generate electricity. Photons become excited when exposed to solar radiation and then release electrons collected by wires to generate a direct current of electricity that most needs to be converted to alternating current using converters (**Leggett, 2009**). The produced energy can be stored using a storage device such as a battery or transmitted to load for utilisation. The device continues to generate energy as long as it is exposed to sunlight.

The photovoltaic effect was first discovered by a French scientist named Alexandre Edmund Becquerel in 1839. The scientist observed while experimenting with metal and electrodes. In the same year, the first photovoltaic cell from selenium wafers with about 1% efficiency was developed by an American inventor called Charles Fritts. In 1888, the first US patent for the photovoltaic cell was received by Edward Weston. In 1901, Nikola Tesla also received another US patent for the technology and a capable methodology utilising solar energy. In 1905, Albert Einstein published the theoretical basis of the photovoltaic effect, which earned him a Nobel Prize in 1921 (**Akinyele et al., 2015**). This critical development was advanced by a Polish scientist called Jan Czochralski in the mid-twentieth century, who developed the silicon cell with 11% efficiency in 1958 at an unaffordable price (USD 1000/W) (**Akinyele et al., 2015**). Baurzhan and Jenkins (2016) reported that the levelized cost of energy generated from the solar photovoltaic system was very high, but the cost has decreased and will continue to decline with the recent technological development. Also, Roche and Ifeanyi-Nwaoha (2017) stated that the solar photovoltaic system's cost drastically dropped by 60% between 2010 and 2015, and the cost of the technology is projected to drop further by 5.9% in 2015. The low cost of technology was due to the higher appetite for the solar photovoltaic electricity harvesting system and massive production (**Sundaram et al., 2016**). With this rapid declination of PV module prices, the technology has a promising future. However, despite this decline in photovoltaics' cost price, some developing countries like Nigeria are yet to utilise the technology's potential and continue to face energy starvation.

The photovoltaic effect occurs when an influx of solar energy hits a cell and gets absorbed by an atom's valence electron, creating pairs of electron holes. The level of electron energy increases according to the amount of photon absorbed. When the photon's energy is greater than the semiconductor bandgap, the electron with excess energy will escape to the conduction band, where it will have freedom of movement. Therefore, the absorption of photon releases an electron that can be collected by employing an electric field across the cell's back and front (**Kalogirou, 2014**). When conductors are attached to this electric field with positive and negative terminals, it forms an electrical circuit, and electrons are collected in form electrical current called

photocurrent ( $I_{ph}$ ). In the absence of illumination, the cell remains inactive and does not produce current. However, if the terminals are connected to a significant external voltage source, the yield is referred to as dark or diode current ( $I_D$ ). Figure 15 illustrates the circuit diagram of an individual cell showing series resistance inside the cell and shunt resistance ( $R_{SH}$ ) from the diode. Considering the aforementioned, the net current is given in Eq. (1) provided by Kalogirou (Kalogirou, 2014).

$$I = I_{ph} - I_D = I_{ph} - I_0 \left\{ \exp \left[ \frac{e(V + I R_S)}{k T C} \right] - 1 \right\} - \frac{V + I R_S}{R_{SH}} \quad (1)$$

Where  $I_0$  is the dark saturation current that strongly depends on ambient temperature,  $e$  is the electronic charge given as  $= 1.602 \times 10^{-19} \text{ J/V}$ ,  $V$  is the imposed voltage across the cell,  $k$  is the Boltzmann's gas constant given as  $= 1.381 \times 10^{-23} \text{ J/K}$ , and  $T$  is the absolute cell temperature.

Even though exposure to temperatures and other environmental factors such as dust formation generally reduce photovoltaic technologies' performance with time, the device is highly reliable and can last for an extended period. Bugaje (1999) reported that a photovoltaic module has an average expected life span of 20–25 years. Conversely, a recent study by Sambo et al. (2014) shows that photovoltaic modules are expected to operate for a period of 30 to 35 years. Solar photovoltaic systems are categorized into first-generation, second generation, and third-generation solar cells (Sundaram et al., 2016).

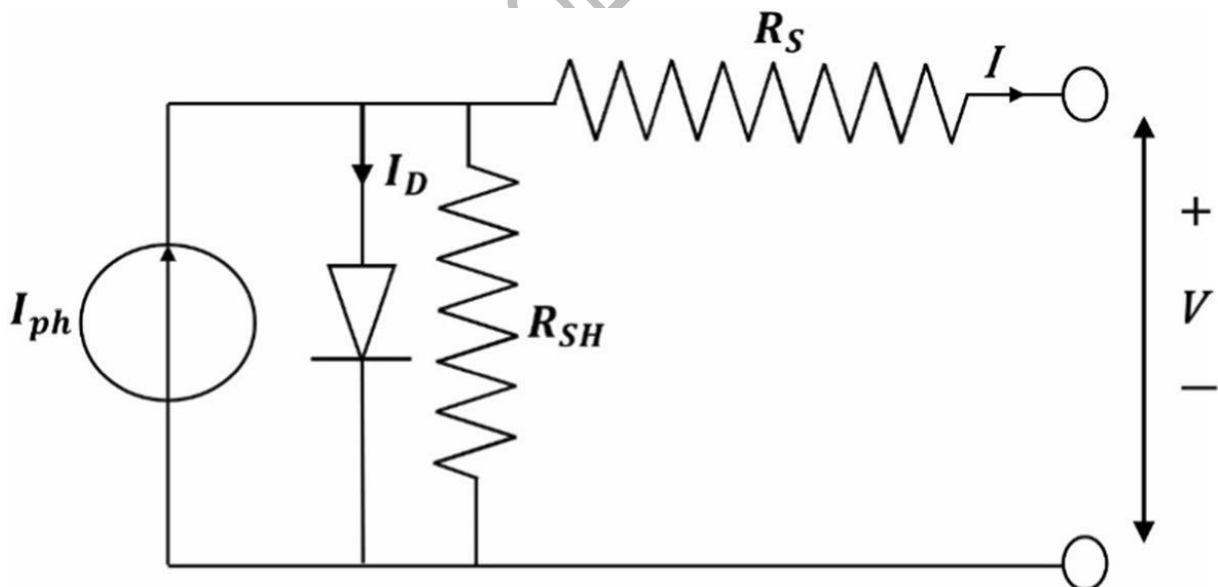

**Figure 3.1** Circuit diagram of a typical solar PV cell (Kalogirou, 2014)

Silicon is a natural resource that is abundantly available across the globe. The first generation is based on silicon and accounts for more than 85% of the photovoltaic industry. This category of photovoltaic is further divided into

three types, according to the design and quality of the silicon, which are: (I) crystalline silicon (c-Si), (ii) polycrystalline (pc-Si), and (iii) thin film (a-Si). These technologies have a high-efficiency rate, with the mc-Si having about 25% efficiency and pc-Si having about 21.5% efficiency (**Akinyele et al., 2015**). These technologies have been on the market for a long time, and their prices are rapidly declining.

The second generation is mainly based on thin film and was developed to optimise material consumption when developing a solar cell. These categories include Copper Indium Gallium Selenide (CIGS), Copper Indium Selenide (CIS), Cadmium Sulphide (CdS/CdTe), and Cadmium Telluride (CdTe) (Akinyele et al., 2015; Sundaram et al., 2016). These are thin layer semiconductors and consume less material when compared to crystalline photovoltaic. The conversion efficiency of these technologies is relatively lower than crystalline technologies. The lower efficiency conversion rate has limited the acceptance of the technology in the photovoltaic market.

Third-generation solar photovoltaic aims to reduce the cost of manufacturing by using more environmentally friendly materials. The technologies under this category are desensitized PV, organic and polymer photovoltaic, nanomaterial-based PVs, and concentrated photovoltaic (**Akinyele et al., 2015; Sundaram et al., 2016**). Due to the mechanical flexibility and materials used, these technologies have lower efficiency than the second generation. These technologies are undergoing intensive research across the globe to improve their conversion efficiency.

## **3.2 Types, Application and Component**

### **3.2.1 Types of Solar Cells**

A lot are already in the market and some are under development. The producers are concerned with making it give maximum power at least cost. Crystalline Silicon cells are dominant in the market. To reduce cost, multi-crystalline materials are now used for its production. Crystalline Silicon cells have long life span. And their efficiency is approaching 18% (**Sambo, 2008**).

Another type of Solar cell is the amorphous thin films which are less efficient and are used to power consumer products like solar watches and calculators. A variety of compound semiconductors like cadmium telluride and copper indium can be used to make thin film cells. These are cheap. A highly specialized and efficient cells are made of gallium arsenide and indium phosphide. They can be used to power satellites and systems under high intensity concentrated sunlight.

### **3.2.2 Applications of Solar PV**

Solar photovoltaic electricity is used for many purposes (to power electrical appliances) and is either used as direct current electricity (DC) or alternating current electricity (AC). Photovoltaic solar power is one of the most promising

renewable energy sources in the World. Compared to nonrenewable sources such as coal, nuclear gas and oil, the advantages are clear:

- (i). Generates free energy from the sun.
- (ii). Has no moving part to break down thus requiring minimal maintenance.
- (iii). Non-polluting energy reduces emissions (has no direct impact on the environment).
- (iv). Photovoltaic cells are modular, giving room for expansion from small systems
- (v). Systems have a long life and durability. Cells last up to 25 years.
- (vi). Grid-Tie systems allow you to sell excess electricity back to the utility

Solar photovoltaic electricity is used in the following areas: lighting; water supply; communications; healthcare; agriculture; satellites, transportation, rural electrification, demonstration projects.

### **3.2.3 Types of PV systems**

There are three general types of electrical designs for PV power systems:

- i). Off-grid stand-alone systems
- ii). Mini-grid systems
- iii). Grid-tie systems (some have battery backups and others have not).

### **3.2.4 Components of a Solar PV System**

#### a) Solar PV array

This is commonly refers to as solar panel. It is responsible for trapping of the solar energy as it is placed outside under the sun. They are arranged in series and parallel to meet desired output.

#### b) Charge Controller

The charge controller is use in controlling the charge (from the word charge control) in the batteries, either to prevent overcharging or discharging.

#### c) Inverter

This is used in converting DC to AC as power from solar PV arrays is in DC form.

#### d) Battery

These are used to store power for usage during the non-sunshine hour. The recommended batteries that should be used in stand-alone photovoltaic power system are deep-cycle lead-acid batteries because of their high performance (**Abu-Jasser, 2010**).

#### e) Balance of System Components

Components such as protective devices, blocking & bypass diodes, lightning-protection system and cable wiring constitute what is known as balance of system components (**Abu-Jasser, 2010**). Such components are necessary to

keep the PV power system safe and reliable. In particular, selecting the correct size and type of cable will enhance the performance of the system while selecting inadequate cable size will cause voltage drop from the source to the load. In low voltage systems, such voltage drops will lead to inefficiencies.

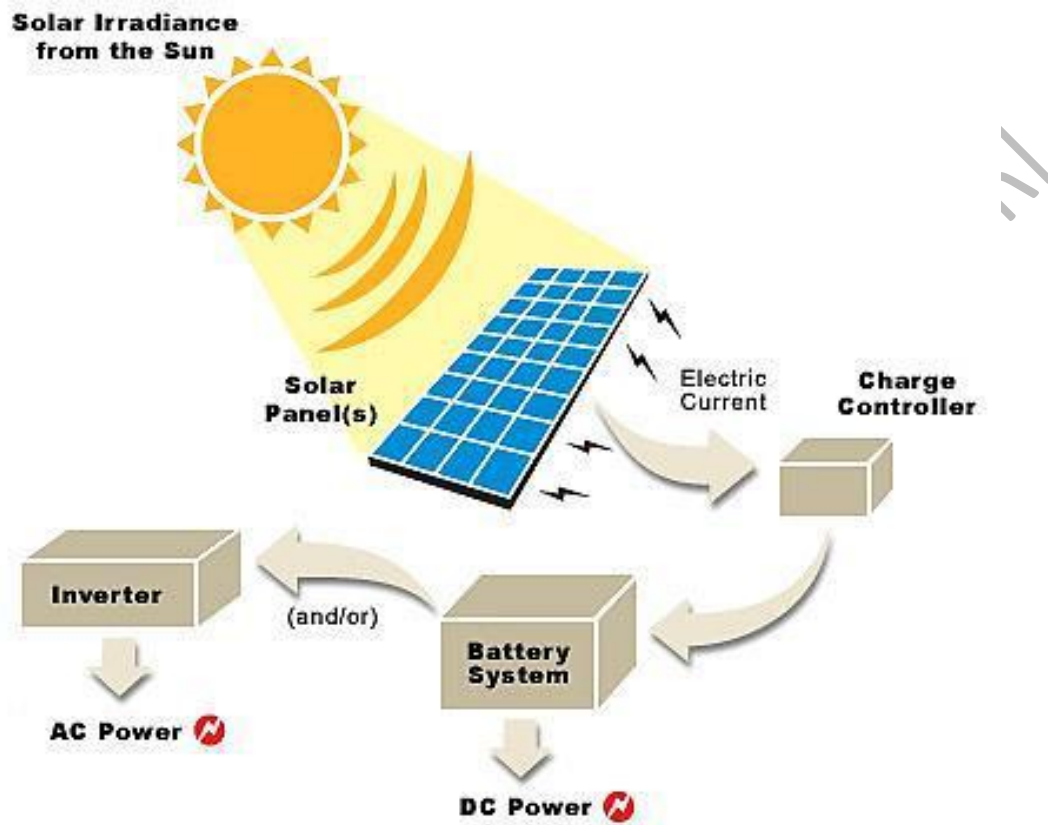

**Fig. 3.2** Pictorial representation of Solar PV system  
Source: Musekaite, Kevelaitis, Obialo and Raudius (2008)

### 3.3 System Modelling

A standalone PV system is considered for modelling. The system configuration of the standalone system or remote area power supply system comprises PV arrays, batteries, inverter, charge controller and balance-of-system. To assess the feasibility and the optimal design of a standalone PV electrification system, the HOMER software<sup>2</sup> was used for the modelling. Optimisation and sensitivity computational algorithms of the HOMER software allow the rapid and robust techno-economic evaluations of various energy technology options by accounting for the cost of energy alternatives and availability of renewable energy resources. The HOMER software has high computation fidelity within the comity of hybrid energy system design

platforms. The HOMER uses the load demand, the resources, the details of the components (with costs), the constraints, the systems control and the emission data as an input to simulate various feasible configurations and ranked by the net present cost (NPC). The NPC, which is the present cost of the system minus the sum of revenues, serves as the objective function, with charging and discharging of the energy storage device, power balance and other techno-economic considerations representing the constraints. HOMER obtains the best system configuration after balancing energy demand and supply for each hour of the system simulation **(Shahzad et al., 2017)** .

The HOMER, which stands for Hybrid Optimisation Model for Electric Renewable, was developed by the US NREL for both grid-tied and stand-alone energy applications. The power output of PV arrays, which generate direct current (DC) voltage when the solar irradiance incident on the PV arrays, can be estimated according to **(Olatomiwa L. 2016) (Lambert T. et al., 2006)**:

$$P_{out} = P_{rated} \times f_{pv} \left( \frac{G}{G_{ref}} \right) \times \left[ 1 + K_{T,pv} (T_c - T_{ref}) \right] \quad (2)$$

Where *rated P* (kW) is rated power of the PV panel at standard test condition (STC), *pv f* (%) is the PV derating factor, *ref G* (kW/m<sup>2</sup>) is the radiation at STC, *G* (kW/m<sup>2</sup>) is the global solar irradiance incident on the PV surface, *T<sub>pv</sub> K* (-) is the temperature coefficient of the PV module, *ref T* (°C) is the cell temperature

at STC and *c T* (°C) is the PV cell temperature. The PV cell temperature can be approximated as *c amb 0.0256 T = T + G* according to Duffie and Beckman, 1991, respectively; where *amb T* is the ambient temperature. It should be noted that the PV module efficiency is moderately dependent on wind and humidity according to **(Kapsali M. et al, 2014) (Bhattacharya T. et al, 2014)**, and as such, the effects of wind and humidity were not considered in the current analysis.

The excess DC power generated by the PV is stored in a battery at fixed round trip efficiency. The battery storage capacity can be computed as follows **(Olatomiwa L. 2016)**:

$$C_{Wh} = (E_L \times D_{aut}) / (\eta_{inv} \times \eta_{Batt} \times DOD) \quad (3)$$

Where *L E*, *aut D*, *inv η*, *Batt η* and DOD are the average daily load energy (kWh/day), the number of days of battery autonomy, the inverter efficiency, the battery efficiency and the battery depth-of-discharge.

The NPC or the Net Present Value (NPV) of a system can be related to the Annualised Life Cycle Cost (ALCC) of the system, which represents the present day worth of money, as **(Olatomiwa L. 2016) (Nnamdi E. et al, 2012)**

$$ALCC = F(i, N)NPC \quad (4)$$

Where  $F(i, N)$  is the system capital recovery factor, which is related as;

$$F(i, N) = \frac{i(1+i)^N}{(1+i)^N - 1} \quad (5)$$

The levelised cost of electricity (LCOE), which represents the average cost per KWh of the electrical energy generated by the system, can be calculated as;

$$LCOE = \frac{ALCC}{E_s} \quad (6)$$

Where  $E_s$  (kWh/year) is the actual electrical energy served by the system.

All the basic technical and economic calculations, Equations (2) through (7), are appended in the HOMER Software computational algorithm.

The economic merit of an energy system could also be measured using the break-even point (BEP) or the payback time (PBT), in years, which accounts for the number of years it would take to fully recover the initial capital investment.

The simple analysis of BEP can be done using Equation (7).

$$BEP = \frac{C_{INV}}{E_s * UEC} \quad (7)$$

Where  $_{INV} C$  (\$) and UEC (\$/kWh) are, respectively, initial capital investment and cost of a unit of electrical energy consumed, which is taken as 0.434 \$/kWh according to the proposed feed-in-tariff presented in the draft Renewable Energy

Master Plan (REMP) of the Energy Commission of Nigeria **(FGN, ECN, and UNDP, 2012)**.

### 3.4 PV Power Plant Characteristic Performance

The International Energy Agency has developed several parameters to examine the performance of photovoltaic power plants (). These parameters define the overall performance of the plant with regard to energy generation, solar resource and the effect of system losses, as shown in Table 1. The parameters include the performance ratio (PR), reference yield (Yr), final yield (Yf), capacity utilization factor (CUF), PV module efficiency, inverter efficiency, and system efficiency.

Parameter	Definition	Formula	Units	Symbol	References
Reference yield	The in-plane irradiation, $H_t$ , divided by the PV reference irradiation, $G$ , gives the reference yield, $Y_r$ . The solar irradiance resource for photovoltaic plants is defined by the $Y_r$ . It is determined by the location, orientation of the photovoltaic array, and seasonal variations.	$Y_r = H_t / G$	kWh/kW per day	$Y_r$	[Sundaram, s. 2015]
Array yield	Array Yield is the energy output of a PV array per kW of installed capacity. It is the difference between the rated PV power and the amount of energy a PV plant generates in a day or month.	$Y_a = E_{pv} DC / P_{rated\ pv}$	kWh/kW per day	$Y_a$	[Sundaram, s. 2015]
Final yield	The final yield, $Y_f$ , is calculated by dividing the total output of AC energy, during a defined time interval, by the installed DC power of the solar array's nameplate. It depicts the time required for the Photovoltaic array to operate at its rated power and produce the same quantity of energy.	$Y_f = E_{pv} AC / P_{max} G$	kWh/kW per day	$Y_f$	[Ayompe L.M, 2011]
Performance ratio	Performance ratio (PR) is the PV plant's final yield divided by the reference yield. The PR is based on the plant's overall losses during the conversion process, which are caused by various components such as cables, solar panels, and the inverter.	$PR = Y_f / Y_r$	%	$Pr$	[Bajracharya, S. 2019]
Capacity utilization factor	For a given time period, the capacity utilization factor (CUF) is defined as	$CUF = E_{ac} / (P_o \times 8760)$	%	CUF	[Obeng, M. 2019]

	the actual output of the photovoltaic power plant divided by the theoretical output of the PV plant for the same period of time.				
PV module efficiency	The module efficiency measures how much energy the solar module converts in contrast to the amount of radiation available.	$\eta_{PV} = E_{dc}/H_t \times St$	%	$\eta_{PV}$	[Dioha, M.O. 2018]
Inverter efficiency	The inverter efficiency is calculated by dividing the AC power generated by the photovoltaic power plant by DC power generated by the inverter	$\eta, Inv = P_{ac}/P_{dc}$	%	$\eta, Inv$	[Dioha, M.O. 2018]
System efficiency	The product of PV module efficiency and inverter efficiency gives the instantaneous PV system efficiency.	$\eta_{sys} = \eta_{PV} \times \eta_{inv}$	%	$\eta_{sys}$	[Attari, K. 2016]
Array capture loss	The array capture loss is the difference between the array yield and the reference yield. A loss occurs when the actual irradiance differs from the reference or theoretical irradiance.	$L_a = Y_r - Y_a$	kWh/kW per day	$L_a$	[Daniel S.A. 2013]
Thermal capture loss	The thermal energy losses that occur when the module temperature increases over 25 degrees Celsius are known as thermal capture losses (Lct). They are calculated using the difference between the reference and adjusted reference yields.	$L_{ct} = Y_r - Y_{cr}$	kWh/kW per day	$L_{ct}$	[Chandel, S.S. 2013]

**Table 3.1** PV power performance parameters.

## Chapter 4

### Performance study of PV Power plant

#### 4.1 Comparative Performance Studies of Different PV Plants

In Table 4.1, a performance analysis of different PV plants is presented, which took the performance parameters, developed in accordance with IEC standards, into consideration. All PV plants in the table are installed in different geographical locations, and they have different monitoring times and durations [Fetyan, K.M. 2021]. Out of the various performance parameters, performance ratio is the key factor for measuring the performance of the PV power system. Performance ratios indicate how effectively the PV power plant is working [Haffaf, A. et al, 2021]. They represent the energy losses that occur at different stages, including array capture loss, inverter loss, wiring loss, and mismatch loss [Aghaei, M. et al, 2020]. The system's components, including inverter efficiency, the cables' characteristics, and its fixed/tracking PV mechanism, are also important factors which play significant roles in the performance of the PV power system. Depending on the rated capacity of PV plants, Table 2 is presented in descending order, from 50 MW to 1.72 kW systems. As per the results of the literature review, only 18% of PV plants showed a performance ratio less than 70%, which is quite satisfactory. In Figure 5, the graph shows the performance ratio per year. Plant observation years are displayed on the horizontal axis, whereas the average performance ratio of the plants observed in the same year is depicted on the vertical axis. Observations show that the performance ratio of the plants is increasing with each passing year [Ameur, A. et al, 2022]. This is because, as technology advances, more precise and effective systems are developed, thus resulting in a higher performance ratio.

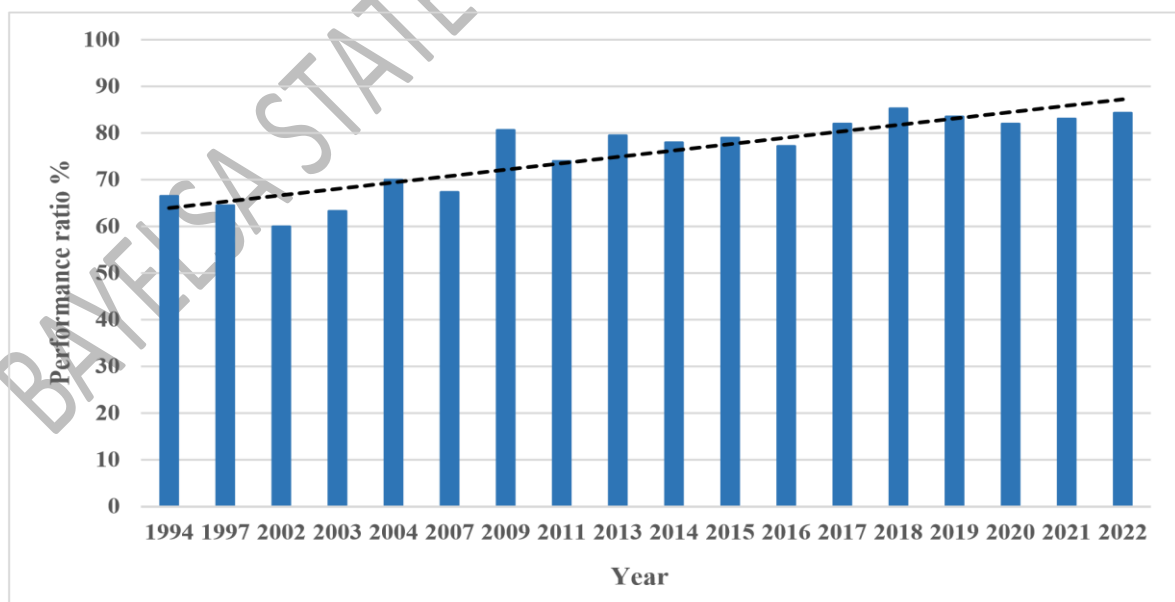

**Figure 4.1** Performance ratio trend with respect to time ( year ).

#### 4.2 Different Factors Affecting PV Power System Performance

A photovoltaic system's output power and lifespan are determined by a number of factors. The type of PV technology used, the amount of solar radiation received, ambience of the temperature, cell temperature, shading effect, dust accumulation, module orientation, weather conditions, and geographical location, are some of the major factors [Farahmand M.Z. et al, 2021]. Figure 4.2 shows the different factors which effect PV efficiency. This paper examines these important factors which affect PV system performance.

### 4.3 Market status and PV quality

Several PV technologies are available on the market, and they are frequently used to generate electricity. These include crystalline silicon (i.e., monocrystalline and polycrystalline) and other thin film technologies, including amorphous silicon, CdTe, CIS, and CIGS. Each technology is suitable for different geographical locations [Udayakumar, M.D. et al, 2021].

In Morocco, authors have compared three different types of PV technology (i.e., (m-si, p-si,a-si)), and they concluded that monocrystalline silicon technologies (m-si) have the best performance in terms of energy production and performance ratio (77%); however, they also note that polycrystalline technology is the most cost effective technology compared with others [Ameur, A. et al, 2022].

In Brazil, in different climatic conditions, six different technologies ( m-si,p-si,CdTe, CIGS, A-si,  $\mu$ c-si) were compared. The thin film technologies (i.e., a-si) have the best PR, reaching up to 90%, although they have the lowest temperature coefficient, whereas the crystalline technologies (m-si, p-si) have the highest temperature coefficient [Do Nascimento, L.R. 2020]. In Abu Dhabi, four rooftop PV systems, which used monocrystalline and polycrystalline technologies, were evaluated. The analysis of the study showed that monocrystalline technologies perform better than polycrystalline technologies [Emziane, M. 2015]. Figures 4.3–4.4 show performance comparison graphs of different PV technologies. Figures 4.4 and 4.4 display performance comparison graphs for various PV technologies. The I-V and P-V parameters for monocrystalline silicon and polycrystalline silicon PV technologies are represented graphically in Figure 4.3 and the impacts of the climate on various PV technologies are shown in Figure 4.4; therefore, these two figures provide a graphical representation of the efficiency traits of various PV technologies. Table 2 includes a summary of the high efficiency of some PV systems. We conclude that thin film technology is more suitable in higher temperature zones than crystalline technology, which is less suitable in these regions, as it is more efficient, and it shows better results. In regions which cultivate moderate or low temperatures, crystalline technologies operate more effectively.

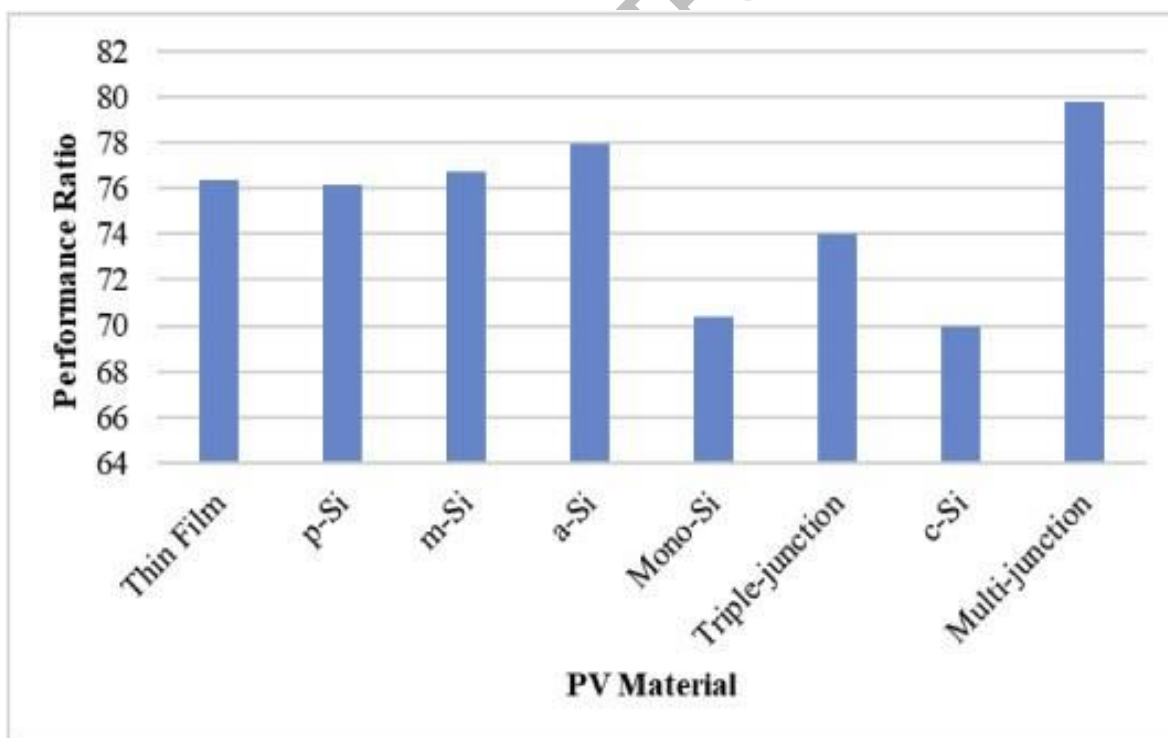

**Figure 4.2** Different, new PV technologies which are available on the market [Akinyele, D.O. 2015].

Type of PV Technology	Performance Efficiency ( % )	Specifications
Poly perc	16 – 17	Comprises multiple silicon crystal cells. On the rear of a cell, a passivation layer is added to increase efficiency.
Mono perc	17 – 19	Consists of a single crystal silicon cell along with Passivated Emitter and Rear Cell technology.
Shingled mono cells	18 – 20	Module cells are cut into five or six strips and connected with an electrically conductive adhesive for conduction.
Half cut mono perc	18–20	A typical module consists of 60 or 72 full cells. Each cell is cut in half and converted into 120 or 144 half cells. It reduces resistance and enhances efficiency by using perc technology.
Half-cut mono perc MBB	19–20.5	MBB denotes that a solar cell has 12 or 16 busbars rather than 4, 5 ,

		or 6. This indicates that the modules have a higher power output and are more reliable.
Shingled mono perc	19–20.5	Along with perc technology, conduction is achieved by cutting module cells into five or six strips and connecting them with electrically conductive adhesive.
Half-cut MBB heterojunction	20–22	Along with a multi-busbar, a HJT is a high-power hybrid cell that combines the finest qualities of crystalline silicon with those of an amorphous silicon thin film to improve efficiency.
N-type IBC	20–23	A thin p-type silicon (doped with boron) layer is layered over a much thicker n-type silicon layer in an N-type solar cell. IBC solar cells, or “interdigitated back contact” solar cells, provide greater efficiency, energy yields, and reliability. The cell is held together by a thick layer of tin-plated copper on the back.

**Table 4. 1** PV technologies which are highly efficient



**Figure 4.3** Performance ratio vs. different PV technologies [Srivastava, R. 2020].

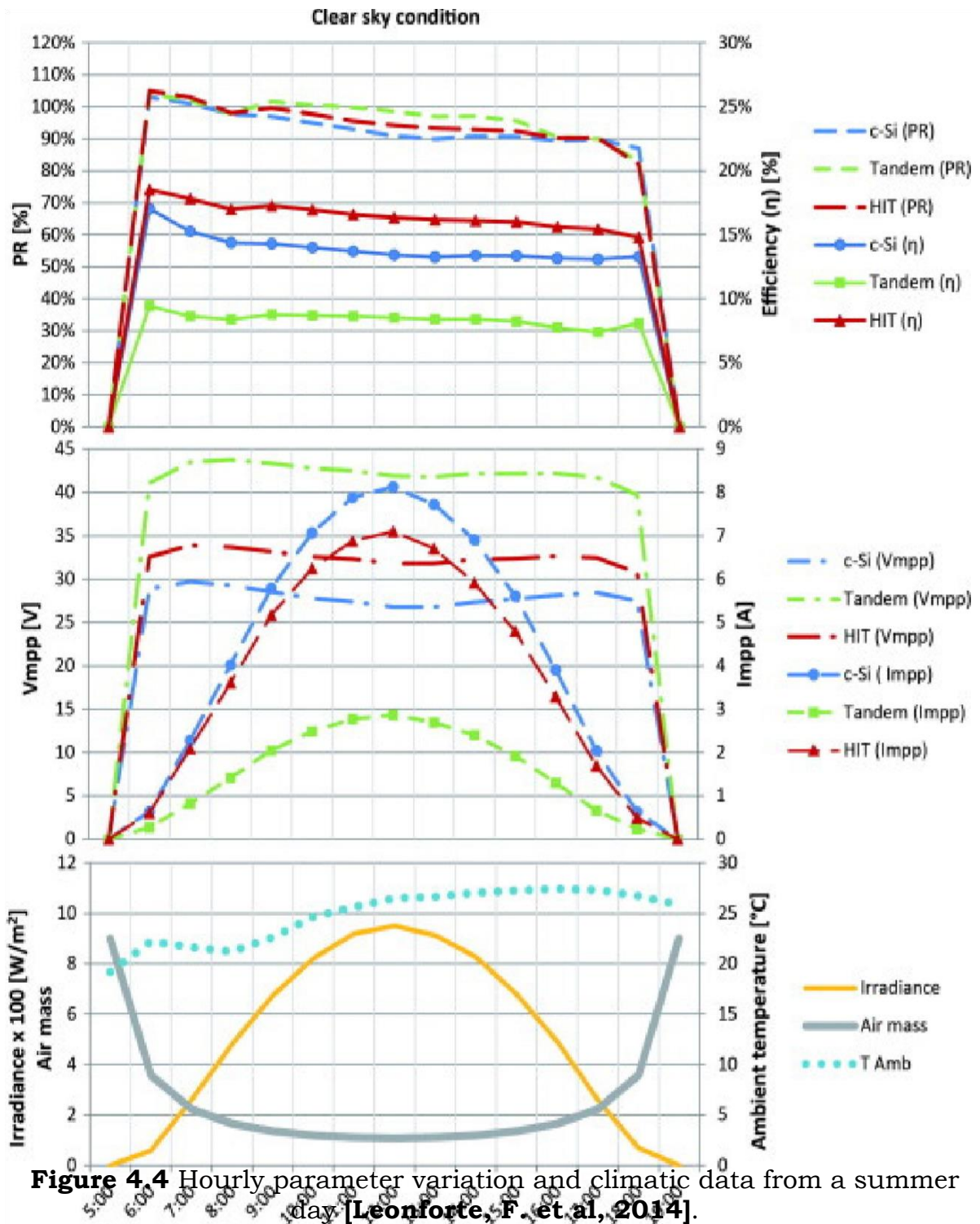

**Figure 4.4** Hourly parameter variation and climatic data from a summer day [Leonforte, F. et al, 2014].

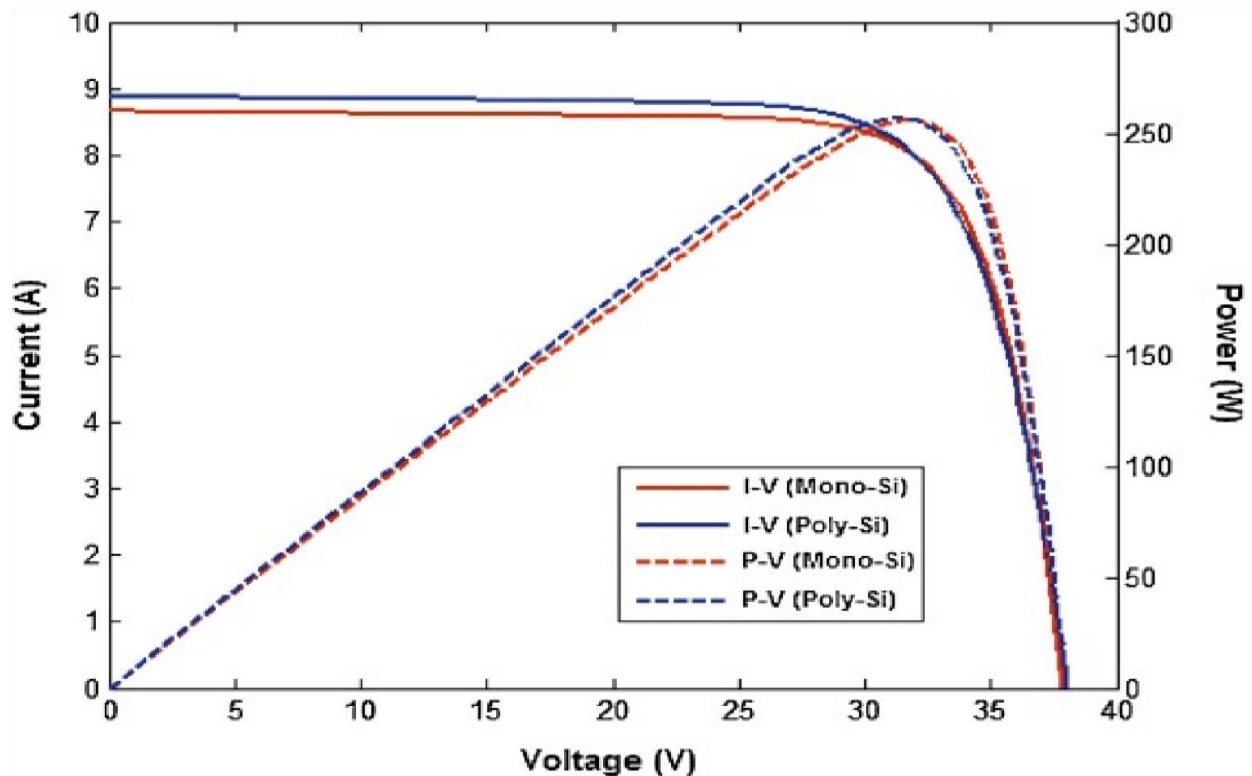

**Figure 4.5** Comparison between Poly-Si and Mono-Si characteristic curves [Allouhi, A. et al, 2016].

#### 4.4 Solar Irradiance

Solar irradiance from the sun has a direct relation to the energy generation of a PV system. The more solar radiation absorbed by the PV modules, the more energy that is produced from the PV system. Different studies have shown that the solar irradiance and power output have a direct relationship [Mondol, J.D. et al, 2007]. To generate more power, the PV modules should be directly facing the sun. According to some studies, each degree of deviation from the south results in a 0.08 percent loss, specifically in the azimuth direction [Chabane, F. et al, 2020]. The electrical power output from the PV panel increases as the solar irradiation increases [Ramadhan, R.A.A. et al 2021]. The module current and solar irradiance have a nearly linear relationship, as the module current increases as the solar irradiance increases [Ramadhan, R.A.A. et al 2021]. In Cyprus, a study was carried out on 14 grid-connected PV systems, which took different levels of solar irradiance into consideration. We conclude that solar irradiance has a significant and direct impact on the power quality behavior of the PV system [Patsalides, M. et al, 2007].

A study analyzes the effect of different outdoor parameters, including solar irradiance, on power output. The regression analysis showed that the solar irradiance has a coefficient of determination of 96.5%, thus indicating that it is the most dominant factor [Al-bashir, A. et al, 2020]. Figure 4.6 shows

different levels of irradiation according to geographical location. Figure 4.7 shows the effect of irradiation on the performance of the PV system. As a function of yearly irradiance on the module plane, the performance ratios for mono-crystalline cells were calculated in the years 1994, 1997, and 2010, as shown in Figure 4.8. When compared with the yearly irradiance, mono-crystalline cells have the lowest performance ratio in 1994, and the highest in 2010. As a result, according to the literature, the influence of solar irradiance on PV panel performance cannot be characterized by a specific percentage increase because the relationship between the module current and irradiance value are approximately linear.

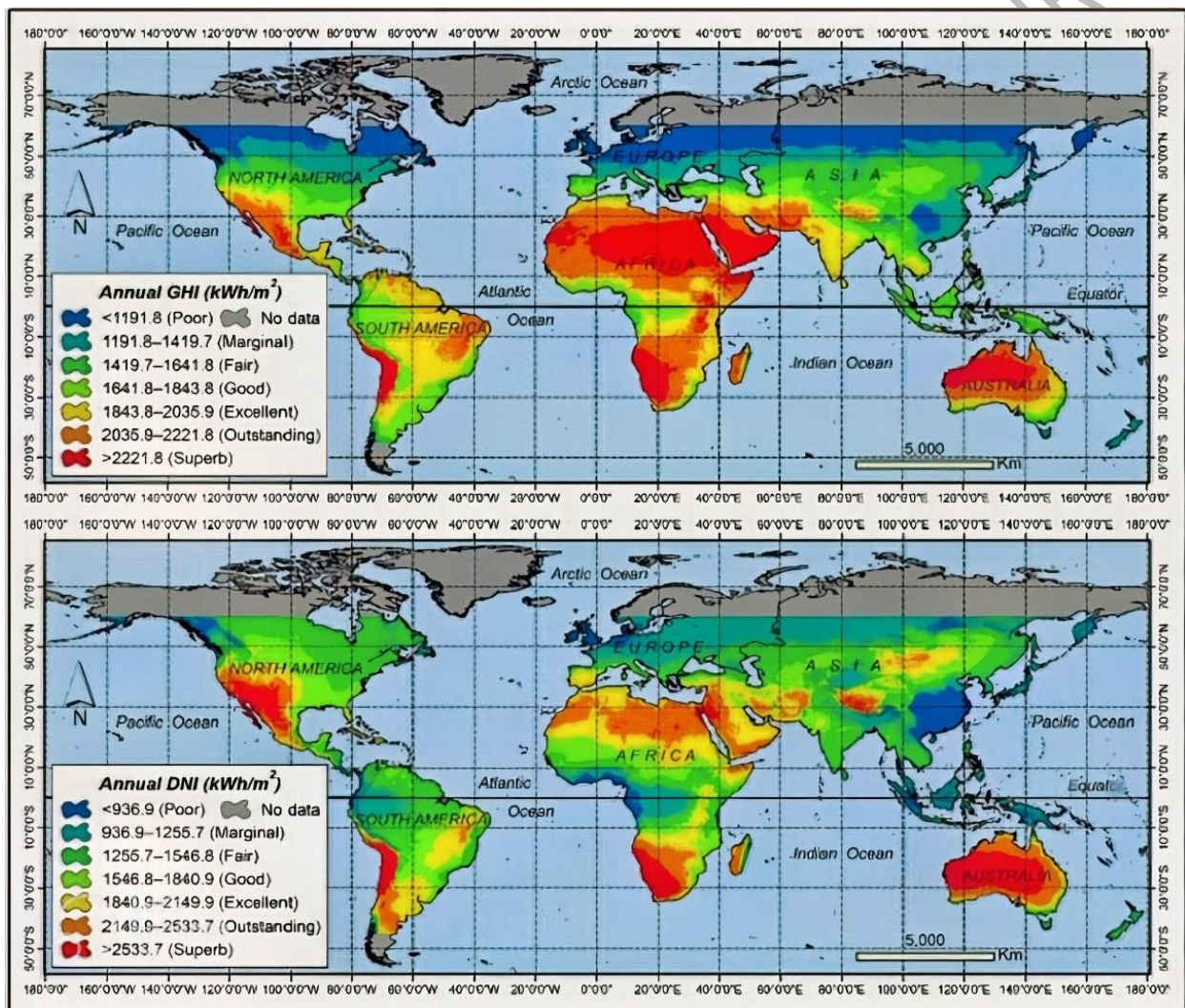

**Figure 4.6** Global spatial representation of global horizontal irradiation (GHI) and direct normal irradiation

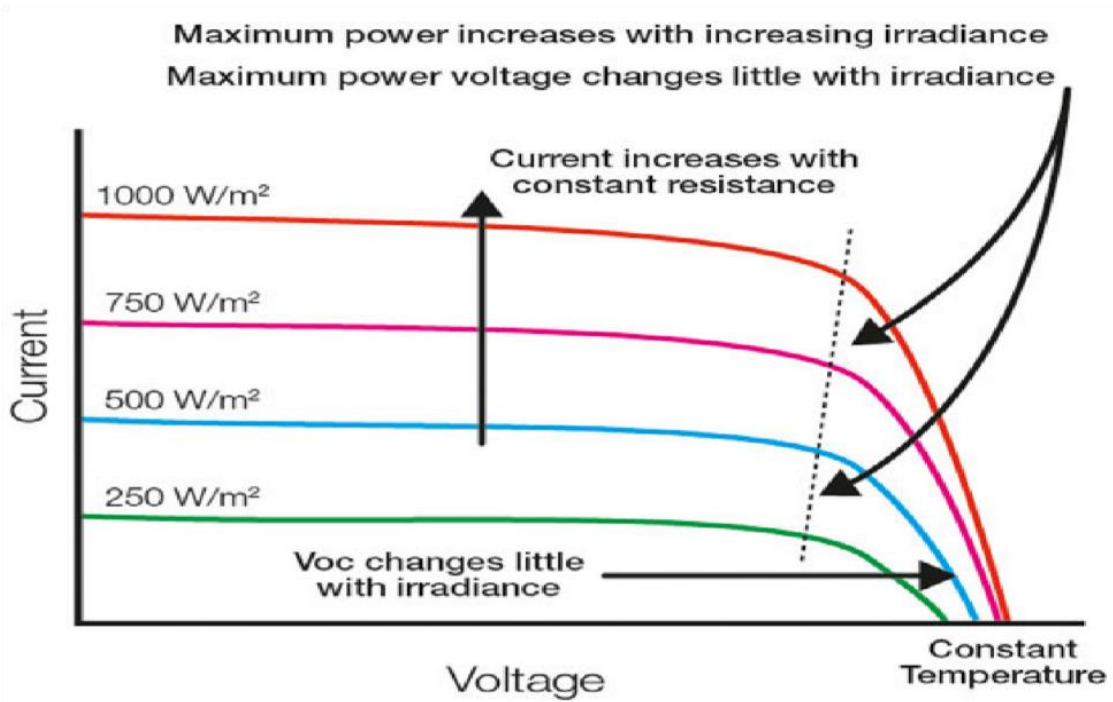

**Figure 4.7** Effect of irradiance on PV system performance.

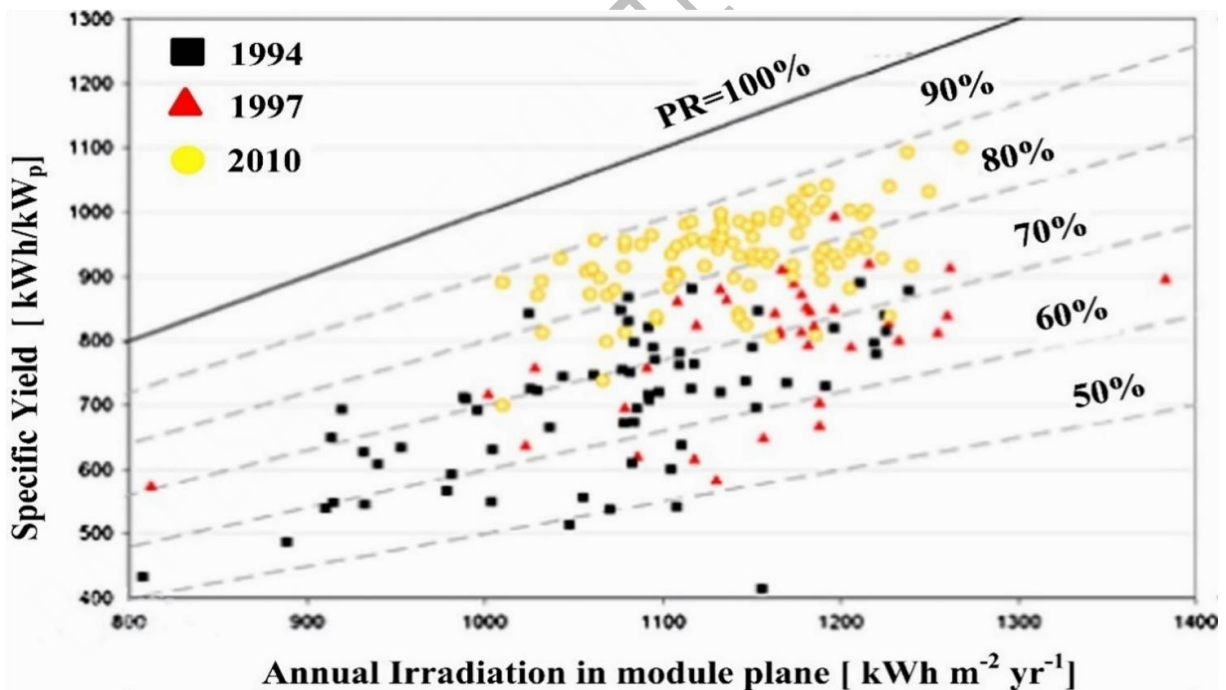

**Figure 4.8** Performance ratio as a function of annual irradiance  
 [Fouad, M.M. et al, 2017].

#### 4.5 Ambient and cell temperature

Due to the incomplete utilization of solar irradiance by the PV power system, the remaining amount of solar irradiance is converted into heat, which causes the PV modules to overheat. Ambient temperature is one environmental factor that negatively affects the PV system's ability to produce power [Roy, P. et al, 2019]. As the ambient temperature increases, the module's surface temperature also increases. Consequently, the cell temperature of the PV module also increases, which causes the operating voltage of the cell to decrease, and the power output of PV system to reduce [Talaat, M. et al, 2022]. According to studies, PV cells lose 0.5% of their efficiency and have a 2.2 mV voltage loss for every 1 °C increase in operational temperature [Meral, M.E. and Diner, F, 2011]. For mono-crystalline PV panels, the typical power temperature coefficients range from 0.38 percent to 0.45 percent/°C, meaning that 0.38 percent to 0.45 percent of power is lost for every 1 °C increase in temperature. In Figures 4.10 and 4.11, different graphs are shown which represent the effect of ambient temperatures and cell temperature on the performance of a PV system. As a result, we conclude that there is no specific range of power losses that is due to PV module temperature increases.

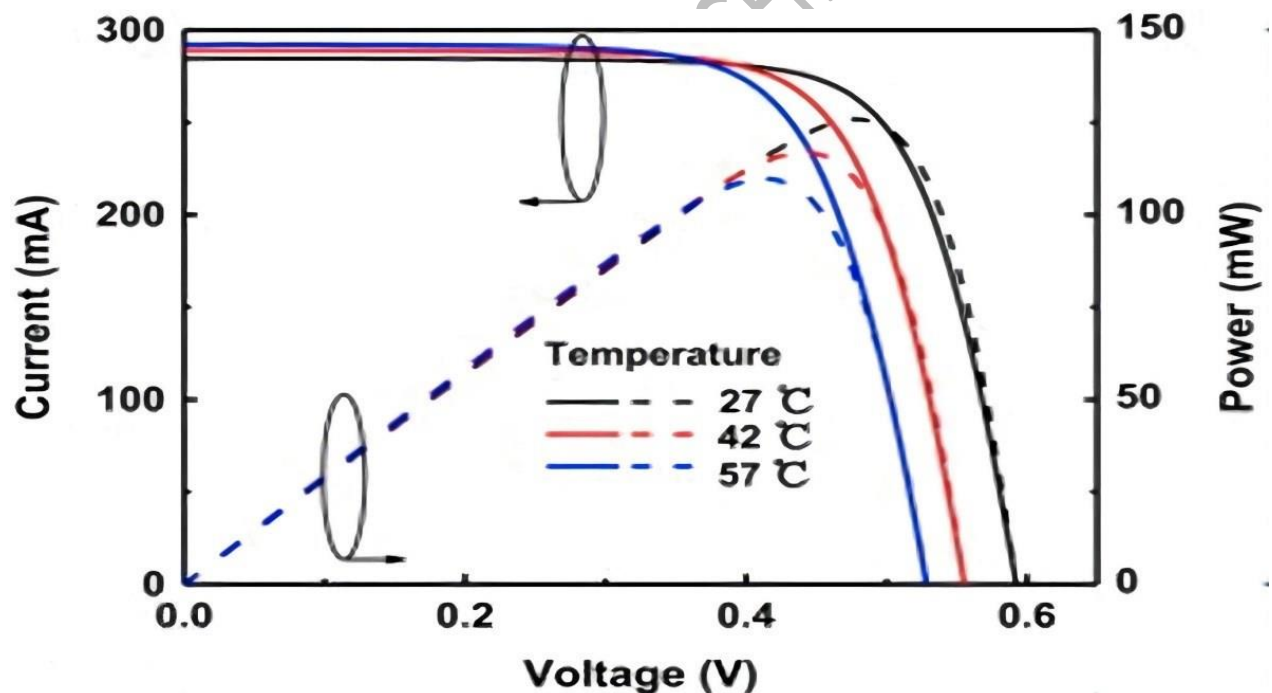

**Figure 4.9** I-V and P-V characteristics of solar cells under a constant irradiance of 1000 W/m<sup>2</sup> at different temperatures [Xiao, C. et al, 2014].

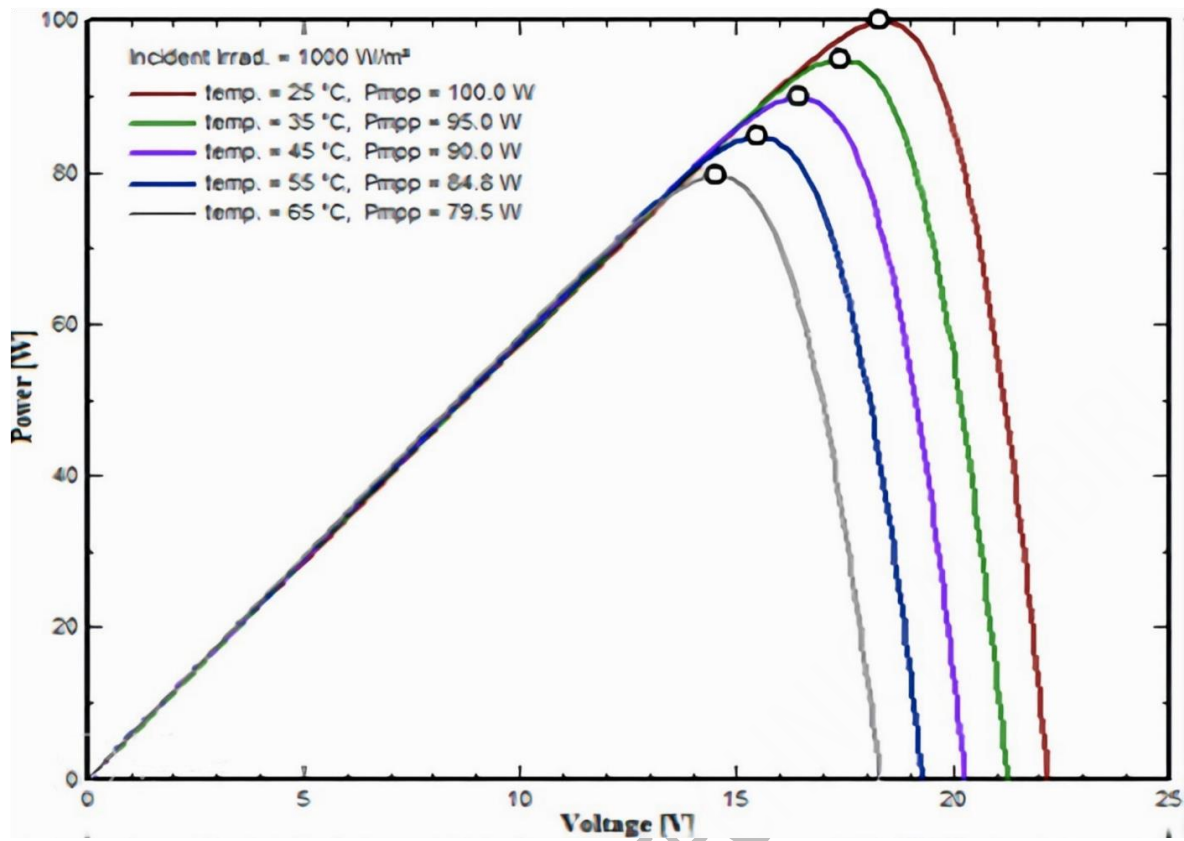

**Figure 4.10** A PV panel's P-V curve characteristics under a constant solar irradiance of 1000 Wm<sup>-2</sup> at different temperatures [Amelia, A.R. et al, 2016].

## **CHAPTER 5**

### **Recommendation, Conclusion and References**

#### **5.1 Recommendations and Future Challenges**

During the last two decades, PV-based electricity generation has become increasingly popular all over the world. PV power systems have emerged as one of the main prospective power supply options. According to this literature review, the following comprise the recommendations and future challenges in this field.

- Enhancing PV technology and efficiency would be more advantageous in terms of greenhouse gas emissions per unit of electricity generated.
- By using photovoltaic power plants as a source of renewable energy-based power production, the level of greenhouse gas emissions will be reduced from what is currently being produced due to fossil-fuel-based power plants.
- Another significant factor to consider when connecting local PV power generation to the grid is power quality, as low power quality can create serious issues for most equipment and financial losses.
- There is a need to focus on harmonic distortion, power factor correction, voltage, and frequency regulation issues.
- To build artificial intelligence-based models for reducing dust accumulation, and to reduce the impact of similar issues, further studies should be conducted. The developed model will help determine the appropriate cleaning strategy based on the model pattern. In addition, hybrid cleaning methods are worth investigating to determine the optimum combination, especially with regard to making the most economical choice and for selecting the best materials.
- In order to make the cell's working conditions more flexible, it would be beneficial to research hybrid cooling technologies that combine many alternative thermal management strategies.
- A hybrid system can use active techniques to boost efficiency during high solar irradiance and ambient temperature periods, while also depending on passive techniques for everyday operations.

## 5.2 Conclusion

There is a growing interest in the development and deployment of renewable energy technologies (RETs) as a result of the rapidly declining cost of solar (PV), the intensified climate change challenges, breakthrough in battery technologies, and energy security. These attributes form the bases for the search for clean, adequate and affordable energy solutions, as stipulated in the No. 7 of the 17 Sustainable Development Goals (SDGs). The rural communities, which are normally in remote and rugged terrain locations, represent the greater percentage of dwelling areas without access to electricity supply, but electricity is required to drive socio-economic developments. Electricity, which is the most demanded energy globally, is required to improve the socio-economic status of rural dwellers. The distributed energy system in which solar PV (PV) is found prominent is favored as a means of solving the rural electrification problems.

Therefore, this paper presents the current PV penetration status in Nigeria and discusses the way forward for aggressive PV penetration in Nigeria energy mix.

The current PV penetration in Nigeria is relatively low and shows a significant gap between the FGN's policy targets and reality. The solar resource potential across the six geo-political zones in Nigeria is also presented—ranges from 3.393 - 6.669 kWh/m<sup>2</sup>/day, with the Northern zones exhibiting better potentials over the Southern zones. It was established that the unit cost of electricity from PV system ranges from 0.387 - 0.475 US\$/kWh, which are well above the unit cost of grid-connected electricity of 0.105 US\$/kWh. However, when issues of reliability, speed of connection and hidden subsidies for grid electrification are considered, the off-grid PV energy solution option shows much promise for rural electrification.

The PV has a competitive economic advantage over diesel generator and glass-covered kerosene lamp for lighting on the basis of their affordability indices. The PV energy system is more affordable in the Northern zones (affordability index ranges from 3.81% - 4.06%) compared with the Southern zones (affordability index ranges from 4.32% - 4.68%). It should be noted that the economy of scale is not considered in the calculation of the affordability index. The household expenditure on PV lighting option, with an affordability index of 4.18%, is the most affordable among the three cases of lighting alternatives considered. It is followed by the glass-covered kerosene lighting device (affordability index of 5.83%) and the least is the diesel generator, with a 9.88% affordability index. The diesel generator and the glass-covered kerosene lamp have a detrimental effect on the environment, which manifest in climate change. The glass-covered kerosene lamp has detrimental effects on indoor air quality that poses danger to the health of the household occupants.

The cost of lighting a rural household under PV electrification is much cost-effective than fossil-fuelled generator and glass-covered kerosene lamp option, even with their detrimental effects on the environment. It can be positioned

that the PV is able to serve medium (7 - 8 kWh/day) and low (under 1 kWh) consumers. The medium consumers would be incentivized to buy into PV because the grid is not reliable, and the low consumers would be driven by the access agenda.

The sensitivity analysis conducted showed that the Federal Government of Nigeria's fiscal and energy policies would accelerate the PV penetration in the country. Specifically, the discount rate on capital investment, PV panel cost and lifespan, and the battery lifespan and cost have been identified to have strong effects on the economic competitiveness of PV energy system. In order to increase the PV penetration in the country, especially in the most energy-deprived areas, the FGN could make the financing of PV systems conducive for low-income households; however, the technical challenges regarding the battery lifespan and cost reside within the global R & D community.

BAYELSA STATE POLYTECHNIC, ALERDUA

## References

Aslam, A.; Ahmed, N.; Qureshi, S.A.; Assadi, M.; Ahmed, N. Advances in Solar PV Systems; A Comprehensive Review of PV Performance, Influencing Factors, and Mitigation Techniques. *Energies* **2022**

Razi, M.; Ali, Y. Social, Environmental and Economic Impacts of Adopting Clean Energy Use. *Int. J. Decis. Support Syst. Technol.* **2019**.

Aslam, A.; Khan, A.N.; Ahmed, N.; Ahmed, N.; Imran, K.; Mahmood, M. Effect of Fixed and Seasonal Tilt Angles on the Performance of an ON-Grid PV Plant. In Proceedings of the 2021 International Conference on Emerging Power Technologies 2021, Topi, Pakistan, 10–11 April 2021.

Sengupta, M.; Habte, A.; Wilbert, S.; Gueymard, C.; Remund, J. *Best Practices Handbook for the Collection and Use of Solar Resource Data for Solar Energy Applications*, 3rd ed.; National Renewable Energy Lab. (NREL): Golden, CO, USA.

Agrawal, M.; Chhajed, P.; Chowdhury, A. Performance Analysis of Photovoltaic Module with Reflector: Optimizing Orientation with Different Tilt Scenarios. *Renew. Energy* **2022**.

Atsu, D.; Seres, I.; Aghaei, M.; Farkas, I. Analysis of Long-Term Performance and Reliability of PV Modules under Tropical Climatic Conditions in Sub-Saharan. *Renew. Energy* **2020**.

Karakaya, E. and Sriwannawit, P. Barriers to the Adoption of Photovoltaic Systems: The State of the Art. *Renewable & Sustainable Energy Reviews* **2015**

Stern, D.I. and Cleveland, C.J. Energy and Economic Growth **2004**.

Dawn, S., Tiwari, P.K., Goswami, A.K. and Mishra, M.K. Recent Developments of Solar Energy in India: Perspectives, Strategies and Future Goals. *Renewable & Sustainable Energy Reviews* **2016**

Wirth, H. Recent Facts about Photovoltaic in Germany **2016**.

Federal Ministry of Power, National Renewable Energy and Energy Efficiency Policy **2015**.

World Bank, Power Outages in Firms in a Typical Month (Number), World Bank Enterprise Survey. World Bank, Washington DC **2015**.

US Energy Information Association, Energy Review. EIA **2016**.

V.N. Udejah, and D.U. Onah, Department of Industrial Physics, Ebonyi State University, Abakaliki, Nigeria **2021**.

Adenikinju, A. F. Electric infrastructure failures in Nigeria: a survey-based analysis of the costs and adjustment responses. *Energy policy* **2003**.

Ajayi, A. B. A survey of solar energy Power Systems. In 8th EEEIC International Conference on Environment and Electrical Engineering, Karpacz, Poland, **2009**.

Akinyele, D. O., Rayudu, R. K., & Nair, N. K. C Global progress in photovoltaic technologies and the scenario of development of solar panel plant and module performance estimation: Application in Nigeria. *Renewable and Sustainable Energy Reviews*, **2015**.

Usman, Z. G., Abbasoglu, S., Ersoy, N. T., & Fahrioglu, M. Transforming the Nigerian power sector for sustainable development. *Energy Policy*, **2015**.

Edomah, N., Ndulue, G., & Lemaire, X. A review of stakeholders and interventions in Nigeria's electricity sector. *Heliyon*, **2021**.

Mohammed, Y. S., Mustafa, M. W., Bashir, N., & Mokhtar, A. S. Renewable energy resources for distributed power generation in Nigeria: A review of the potential. *Renewable and Sustainable Energy Reviews*, **2013**.

Sambo, A. Strategic Developments in Renewable Energy in Nigeria. *Research Gate*, **2009**.

Leggett, J. *The Solar Century: The Past, Present and World-Changing Future of Solar Energy* London **2009**.

Sundaram, S.; Babu, J.S.C. Performance Evaluation and Validation of 5 MWp Grid Connected Solar Photovoltaic Plant in South India. *Energy Convers. Manage.* **2015**.

Sambo, A.S. The Role of Energy in achieving Millenium Development Goals (MDG): Keynote Address of the *National Engineering Conference (NETEC)*, Ahmadu Bello University, Zaria, 1st April, **2008**.

Abu-Jasser, A. A stand-alone photovoltaic system, case study: a residence in Gaza. *Journal of Applied Sciences in Environmental Sanitation* **2010**.

Shahzad, M.K., Zahid, A., Rashid, T., Rehan, M.A., Ali, M. and Ahmad, M. Techno-Economic Feasibility Analysis of a Solar-Biomass off Grid System for the

Electrification of Remote Rural Areas in Pakistan Using HOMER Software. *Renewable Energy*, **2017**.

Olatomiwa, L. Optimal Configuration Assessments of Hybrid Renewable Power Supply for Rural Healthcare Facilities. *Energy Reports*, **2016**.

Lambert, T., Gilman, P. and Lilienthal, P. Micropower System Modeling with Homer. In: Farret, F.A. and Simoes, M.G., Eds., *Integration of Alternative Sources of Energy*, John Wiley and Sons, Hoboken, **2006**.

Kapsali, M. and Kavadias, K.A. Temperature and Wind Speed Impact on the Efficiency of PV Installations. Experience Obtained from Outdoor Measurements in Greece. *Renewable Energy*, **2014**.

Bhattacharya, T., Chakraborty, A.K. and Pal, K. Effects of Ambient Temperature and Wind Speed on Performance of Monocrystalline Solar Photovoltaic Module in Tripura, India. *Journal of Solar Energy*, **2014**.

FGN, ECN, and UNDP Draft Renewable Energy Master Plan **2012**.

Ayompe, L.M.; Duffy, A.; McCormack, S.J.; Conlon, M. Measured Performance of a 1.72 KW Rooftop Grid Connected Photovoltaic System in Ireland. *Energy Convers. Manag.* **2011**.

Man Bajracharya, S.; Maharjan, S. Techno Economic Analysis of Grid Tied Solar System: A Case Study of Nepal Telecom. Sundhara Kathmandu **2019**.

Obeng, M.; Gyam, S.; Sarfo, N.; Kabo-bah, A.T. Technical and Economic Feasibility of a 50 MW Grid-Connected Solar PV at UENR Nsoatre Campus. *J. Clean. Prod.* **2019**.

Dioha, M.O.; Kumar, A. Rooftop Solar PV for Urban Residential Buildings of Nigeria: A Preliminary Attempt towards Potential Estimation. *AIMS Energy* **2018**.

Fetyan, K.M.; Hady, R. Performance Evaluation of On-Grid PV Systems in Egypt. *Water Sci.* **2021**.

Haffaf, A.; Lakdja, F.; Ould Abdeslam, D.; Meziane, R. Monitoring, Measured and Simulated Performance Analysis of a 2.4 KWp Grid-Connected PV System Installed on the Mulhouse Campus, France. *Energy Sustain. Dev.* **2021**.

Aghaei, M.; Kumar, N.M.; Eskandari, A.; Ahmed, H.; de Oliveira, A.K.V.; Chopra, S.S. Chapter 5—Solar PV systems design and monitoring. *Photovolt. Sol. Energy Convers.* **2020**.

Ameur, A.; Berrada, A.; Bouaichi, A.; Loudiyi, K. Long-Term Performance and Degradation Analysis of Different PV Modules under Temperate Climate. *Renew. Energy* **2022**.

Farahmand, M.Z.; Nazari, M.E.; Shamlou, S.; Shafie-khah, M. The Simultaneous Impacts of Seasonal Weather and Solar Conditions on PV Panels Electrical Characteristics. *Energies* **2021**.

Udayakumar, M.D.; Anushree, G.; Sathyaraj, J.; Manjunathan, A. The Impact of Advanced Technological Developments on Solar PV Value Chain. *Mater. Today Proc.* **2021**.

Do Nascimento, L.R.; Braga, M.; Campos, R.A.; Napolini, H.F.; R  ther, R. Performance Assessment of Solar Photovoltaic Technologies under Different Climatic Conditions in Brazil. *Renew. Energy* **2020**.

Emziane, M.; Al Ali, M. Performance Assessment of Rooftop PV Systems in Abu Dhabi. *Energy Build.* **2015**.

Srivastava, R.; Tiwari, A.N.; Giri, V.K. An Overview on Performance of PV Plants Commissioned at Different Places in the World. *Energy Sustain. Dev.* **2020**.

Allouhi, A.; Saadani, R.; Kousksou, T.; Saidur, R.; Jamil, A.; Rahmoune, M. Grid-Connected PV Systems Installed on Institutional Buildings: Technology Comparison, Energy Analysis and Economic Performance. *Energy Build.* **2016**.

Mondol, J.D.; Yohanis, Y.G.; Norton, B. The Impact of Array Inclination and Orientation on the Performance of a Grid-Connected Photovoltaic System. *Renew. Energy* **2007**.

Chabane, F.; Moumami, N.; Brima, A. A New Approach to Estimate the Distribution of Solar Radiation Using Linke Turbidity Factor and Tilt Angle. *Iran. J. Sci. Technol.-Trans. Mech. Eng.* **2020**.

Ramadhan, R.A.A.; Heatubun, Y.R.J.; Tan, S.F.; Lee, H.J. Comparison of Physical and Machine Learning Models for Estimating Solar Irradiance and Photovoltaic Power. *Renew. Energy* **2021**.

Patsalides, M.; Evagorou, D.; Makrides, G.; Achillides, Z.; Georghiou, G.E.; Stavrou, A.; Efthimiou, V.; Zinsser, B.; Schmitt, W.; Werner, J.H. The Effect of Solar Irradiance on the Power Quality Behaviour of Grid Connected Photovoltaic Systems. *Renew. Energy Power Qual. J.* **2007**.

Al-bashir, A.; Al-Dweri, M.; Al-ghandoor, A.; Hammad, B.; Al-kouz, W. Analysis of Effects of Solar Irradiance, Cell Temperature and Wind Speed on Photovoltaic Systems Performance. *Int. J. Energy Econ. Policy* **2020**.

Fouad, M.M.; Shihata, L.A.; Morgan, E.I. An Integrated Review of Factors in Influencing the Performance of Photovoltaic Panels. *Renew. Sustain. Energy Rev.* **2017**.

Roy, P.; Sinha, N.K.; Khare, A. An Investigation on the Impact of Temperature Variation over the Performance of Tin-Based Perovskite Solar Cell: A Numerical Simulation Approach. *Mater. Today Proc.* **2019**.

Talaat, M.; Said, T.; Essa, M.A.; Hatata, A.Y. Integrated MFFNN-MVO Approach for PV Solar Power Forecasting Considering Thermal Effects and Environmental Conditions. *Int. J. Electr. Power Energy Syst.* **2022**.

Meral, M.E.; Diner, F. A Review of the Factors Affecting Operation and Efficiency of Photovoltaic Based Electricity Generation Systems. *Renew. Sustain. Energy Rev.* **2011**

Xiao, C.; Yu, X.; Yang, D.; Que, D. Impact of Solar Irradiance Intensity and Temperature on the Performance of Compensated Crystalline Silicon Solar Cells. *Sol. Energy Mater. Sol. Cells* **2014**.

Amelia, A.R.; Irwan, Y.M.; Leow, W.Z.; Irwanto, M.; Safwati, I.; Zhafarina, M. Investigation of the Effect Temperature on Photovoltaic (PV) Panel Output Performance. *Int. J. Adv. Sci. Eng. Inf. Technol.* **2016**.